

**8165**

**6 1/2 Digital Multimeter  
User's Manual**



## Safety Precautions

Make sure that you use this product as specified to avoid personal injury and product damage, and do not go to the next step before fully understanding and meeting the following warnings.

- ◆ **Safety grounding.** Please make sure that the power-line grounding terminal is reliably connected to the protective grounding terminal of the product. Inset the instrument into the grounded power outlet.
- ◆ **Use fuses properly.** In order to provide continuous fire protection, please only use the fuses of specified types and rated values.
- ◆ **Front/rear switch safety items.** When there are signals on front/rear terminal set, please do not change positions of front/rear switch on the front panel. Generally the switch can not be used as a movable multiplexer, and switchover under high voltage or high current may cause instrument damage or may cause electric shock.
- ◆ **Correctly use leading wire suite.** Please do not use damaged or worn-out leading wire suite, which may cause instrument damage or personal injury. During probe using, the fingers should be kept behind finger-protecting device of the probe. While wiring, firstly connect the common line and then the charged testing line, and while disconnecting, firstly disconnect the charged testing line.
- ◆ **If the product works in disorder, please do no use.** The product's protecting devices may be damaged, and do not install substitute parts or adjust the product arbitrarily. Please return the product for maintenance or ask professionals to inspect to ensure its security feature.
- ◆ **The product can by no means be used in flammable and combustible environment.**
- ◆ **Protection limits.**

Under the condition of not exceeding protection limits, the protection circuitry provided by this product can prevent instruments from being damaged or electrically shocked. In order to ensure safe instrument operation, please do not exceed the protection limits indicated on the front and rear panels, defined as follows:

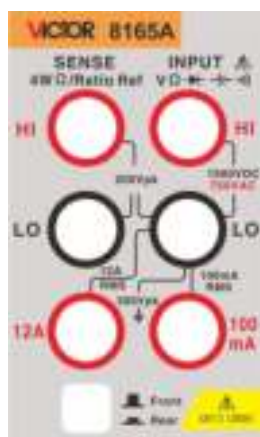

**Note:** What showed in the above figure is front panel terminal, and rear panel terminal is basically the same as the front panel terminal but without 12A-current shift, with current-protection fuse on the rear panel.

Protection limits of input terminal are as follows:

**Main input (HI and LO) terminals.**

HI and LO input terminals are used in voltage, resistance, capacitance, continuity, frequency and diode test, and the protection limits of the two terminals are as follows:

- 1) Protection limit from HI to LO. Protection limit from HI to LO is 1000 VDC or 750 VAC, which is the maximum measurable voltage. The limit can also be expressed as 1000Vpk at most.
- 2) Protection limit from LO to grounding. Relative to grounding LO input terminal can safely “float” to 500Vpk at most.

**Protection limit of sense terminals**

HI and LO sense terminals are only used in 4-wire resistance and ratio measurement. Protection limit for all the terminal pairs is 200Vpk, and all the terminal pairs refer to LO SENSE to LO INPUT, HI SENCE to LO INPUT, and HI SENSE to LO SENSE.

Current input (10A and 400mA) terminals.

10A terminal and LO terminal are used in current measurement of 1A and 12A measurement ranges, and fuses inside the multimeter provide 15A protection limit at most to the current through 12A terminal. 100mA terminal and LO terminal are used in current measurement of measurement range from 10uA to 100mA, and current input fuses on the rear panel provide 500mA protection limit at most to the current through 100mA terminal.

**Note:**

In order to avoid fuse blowout and multimeter damage, please use current input terminals as indicated as follows.

- 1) 12A and 100mA input terminals are not allowed to be connected to the current measurement loops at the same time.
- 2) If the valid values of currents to be measured AC+DC are from 100mA to 12A, and only 12A and LO terminals are allowed to be used in measurement.
- 3) When measuring current, please correctly select the current input terminals according to the predicted current size before connecting multimeter power.
- 4) Current input to 12A terminal can not exceed 15A at most, otherwise fuses inside multimeter will be blown out; current input to 400mA terminal can not exceed 500mA at most, otherwise current input fuses on rear panel will be blown out.

◆ **IEC measurement category II overvoltage protection.**

In order to avoid electric shock, the product provides overvoltage protection in connection of the mains which meet the following two conditions at the same time;

1. HI and LO input terminals are connected to mains under the measurement category II conditions (as described in the following).
2. The maximum line voltage of mains is 300VAC.

Warning: IEC measurement category II includes electric devices connected to mains through an outlet on branch circuit. Such devices include most small appliances, test equipment, and other devices that plug into branch outlets.

The product can be used in such measurements: HI and LO input terminals connect to mains in these devices (maximum 300VAC) or to the branch outlets. However, the HI and LO input terminals of this product can not be connected to mains in permanently-installed electric devices, such as main circuit-breaker panel, sub-panel disconnect boxes, or permanently wired motors. Such devices and circuits are easily subject to overvoltages that may exceed the protection limits of the product.

Note: Voltages above 300 VAC may be measured only in circuits that are isolated from mains. However, transient overvoltages are also present on circuits that are broken from mains. The product is designed to safely withstand occasional transient overvoltages up to 2500 Vpk. Do not use this equipment to measure circuits where transient overvoltages could exceed this level.

## Environmental Precautions

The product complies with requirements indicated in WEEE Directive (2002/96/EC). The affixed product label (see below) indicates that you must not discard this electrical/electronic product along with domestic household waste.



**Product category:** With reference to the equipment types specified in the WEEE directive Annex 1, this product is classified as "Monitoring and Control Instrument" product.

Some substances contained in the product may be harmful to environment or human body. In order to avoid hazardous substances releasing to environment or endangering human body, it is recommended to recycle the product in a proper way to make sure that most of materials can be correctly re-used or recycled. Contact local authority for disposal or recycling information.

## Symbols on Product

The following symbols may appear on products:



Signal Ground



Chassis Ground



High Voltage



Reference Manual

## Brief Introduction to 8165A and 8165 Digit Multimeter

8165A or 8165 multimeter provides 6 1/2digits, high-performance AC and DC measurements. The multimeter is equipped with a 3.5-inch color display with high resolution and built-in intelligent operation system, and is able to provide more information and functions, simpler operation, wider testing range and more flexible and convenient system building. It is a new digit multimeter that leads the developing tendency above.

They are mainly characterized by:

- ◆ 6 1/2 resolution (8165A/8165)
- ◆ The digital multimeter is equipped with a 3.5-inch color display screen (resolution ratio is 320\*480), which is powerful enough to provide greater coverage of content, flexible display of a variety of graphical interface, and good display effects. The users can also customize the display interface depending on their needs, and choose from various display functions such as graphics, figures, maths and other functions simultaneously on the screen.
- ◆ Bi-parameter display can display two parameters in one input signal (such as display AC voltage value and AC frequency value during AC voltage measurement).
- ◆ Conduct remote operation through interfaces of IEEE 488 (8165A), RS-232, LAN and USB Device.
- ◆ With functions of trigger input and output of measuring completion.
- ◆ The front-panel menu is with USB port for data storage, procedure updating and configuration.
- ◆ Customers can update host software by themselves.
- ◆ Two-wire and four-wire measurement for resistance, 10Ω and 1GΩ measurement range for extension.
- ◆ Measurement of period and frequency, and frequency can reach to 300 kHz.
- ◆ Capacitance measurement.
- ◆ For temperature measurement, users can set sensor measurement by themselves.
- ◆ Maximum current measurement capacity reaches up to 12A.
- ◆ Many math functions: statistics (maximum value, minimum value and average value), zero elimination, dB, dBm and limit.
- ◆ Graphic display: tendency chart, histogram, history curve, listing and other display methods.
- ◆ Support SCPI programming language and many command sets (Agilent 34401A and Fluke 45).
- ◆ With internal and external calibration functions.

### Basic difference:

8165A	8165
With GPIB interface	Without GPIB interface
With rear panel signal input terminal	Without rear panel signal input terminal

# Contents

1. Quick Start .....	8
1.1 Inspect Product Accessories .....	8
1.2 Front Panel .....	8
1.3 Rear Panel .....	10
1.4 Adjust Handles .....	11
1.5 Start Multimeter .....	11
1.6 User Interface .....	12
1.7 Measurement Wiring .....	13
2. Basic Operations of Front Panel .....	15
2.1 Conduct Basic Measurement .....	15
2.1.1 DC voltage measurement .....	15
2.1.2 DC voltage ratio measurement .....	16
2.1.3 AC voltage measurement .....	17
2.1.4 DC current measurement .....	18
2.1.5 AC current measurement .....	19
2.1.6 Resistance measurement .....	20
2.1.7 Frequency/Period measurement .....	21
2.1.8 Capacitance measurement .....	22
2.1.9 Continuity measurement .....	23
2.1.10 Diode measurement .....	23
2.2 Usage of Sensor .....	24
2.2.1 Thermal resistance sensor .....	24
3. Characteristic and Function .....	24
3.1 Measurement Configuration .....	24
3.1.1 AC signal filter .....	24
3.1.2 Continuity threshold resistance .....	25
3.1.3 DC input resistance .....	25
3.1.4 Resolution .....	26
3.1.5 Integral time .....	27
3.1.6 Switch between front/rear input terminals .....	27
3.1.7 Auto zero calibration .....	27
3.1.8 Select measurement range (measurement shift) .....	28
3.2 Math Operation .....	28
3.2.1 Relative (zero) operation .....	29
3.2.2 dBm value measurement .....	30
3.2.3 dB value measurement .....	30
3.2.4 Limit test .....	31
3.3 Trigger .....	32
3.3.2 Reading holding .....	33
3.3.3 Trigger parameter setting .....	34
3.3.4 Trigger output .....	34

3.4 Data Record .....	35
3.5 Relevant System Operations .....	35
3.5.1 System setting .....	35
3.5.2 Command set .....	36
3.5.3 Topic .....	36
3.5.4 Self-test .....	36
3.5.5 Calibration .....	37
3.5.6 System information inquiry and system updating .....	37
4. Conduct Remote Control .....	37
4.1 GPIB Interface Configuration (Only Supported By 8165A) .....	37
4.2 RS232 Interface Configuration .....	38
4.3 USB Interface Configuration .....	38
4.4 LAN Interface Configuration .....	38
5. Measurement Guide .....	39
5.1 DC Measurement Considerations .....	39
5.1.1 Thermoelectromotive force error .....	39
5.1.2 DCV load error .....	39
5.1.3 DCI load error .....	40
5.1.4 Noise control .....	40
5.1.5 Resistance measurement considerations .....	42
5.2 AC Measurement Considerations .....	42
5.2.1 True virtual value AC measurement .....	42
5.2.2 Crest factor error (non-sine wave input) .....	43
5.2.3 ACV load error .....	44
6. Indicators .....	44
6.1 DC Characteristics .....	45
6.1.1 Basic characteristics .....	45
6.2 Uncertainty Indicators .....	47
6.2.1 Additional error .....	48
6.3 AC Characteristics .....	48
6.3.1 Basic characteristics .....	48
6.3.2 Uncertainty indicators .....	49
6.3.3 Additional error .....	50
6.4 Frequency and Period Characteristics .....	50
6.4.1 Uncertainty indicators .....	50
6.4.2 Low-frequency additional error .....	51
6.5 Capacitance .....	51
6.6 Temperature .....	51

## 1. Quick Start

### 1.1 Inspect Product Accessories

Confirm that multimeter is attached with the following subjects, among which the optional accessories can be attached to products only after purchasing. If any subject is missed, please contact the closest sale office.

#### Standard equipped accessories:

- One set of hard-spot testing line and a 2mm probe
- One piece of double-end three-core power line
- One pair of alligator clips
- Two pieces of backup power fuses

- User manual

#### Optional equipped accessories:

- GPIB cable
- Cabinet-installing suite
- PT100 temperature probe
- RS232 serial port line
- USB data line

### 1.2 Front Panel

This 6 1/2 digit multimeter provides a 480\*320 TFT display, and the equipped display can indicate current working status, F1-F5 software define area, measured value, etc.

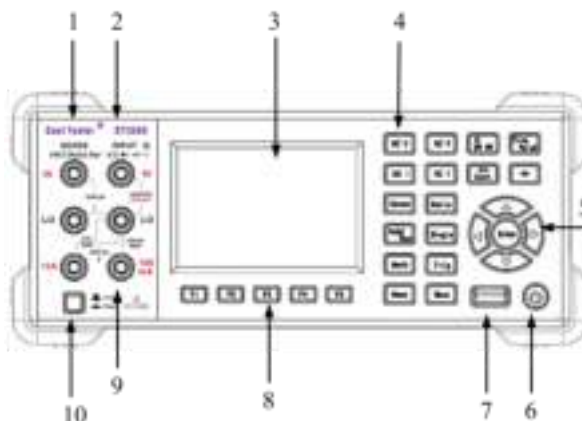

No.	Introduction
1	HI and LO sense input terminals. Use 4-wire resistance voltage to measure the input, or refer to ratio measurement for voltage input.
2	HI and LO main input terminal, all functions exclusive of current)
3	480×320 TFT LCD
4	Function keys of digit multimeter. Select functions of digit multimeter, such as DC voltage, AC voltage, DC current, AC current, resistance, continuity, diode test, frequency, period, capacitance, ratio and sensor.
5	Direction and enter key can set measurement range and measurement rate in normal measurement interface and can be used in menu selection and numeric value setting in menu.
6	Soft power switch.
7	USB HOST interface is used for procedure updating and data storage.



8	F1-F5 softkeys. Softkeys are used to select different menu options in digit multimeter menu. Each softkey function is indicated by the label at screen bottom, and softkeys which are not indicated by labels on the screen are invalid.
9	100mA and 12A input connection ends are used in AC and DC current measurement
10	Front/rear switch

Keys are classified into three main categories, that is, function key, setting key and redefine key, among which function key is used to quickly select needed measurement function, setting key to set system and function parameters, and redefine key to redefine by application program according to changes of measurement functions.

Function key includes all the basic measurement function keys of DC voltage, DC current, AC voltage, AC current, resistance 2-wire, resistance 4-wire, frequency, period, on-off, diode, sensor, capacitance and ratio, among which resistance 2-wire and resistance 4-wire share one key, frequency and period share one, and on-off and diode share one.

Setting key is to set parameters of current measurement function or system. Frequently-used settings solely using one key is placed on the panel for quick setting; those non-frequently-used settings are placed in general setting key and operated through menu. The frequently-used ones include math function, trigger setting, holding, operating, single trigger, measurement setting, etc.

Softkey includes 5 redefine keys to redefine by application program as required under different functions.

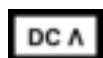

: Select DC voltage measurement.



: Select AC voltage measurement.



: Select DC current measurement.



: Select AC current measurement.



: Select 2-wire or 4-wire resistance measurement.



: Select frequency or period measurement.



: Select capacitance measurement.



: Select continuity measurement or diode measurement.



: Select sensor measurement.



: Select ratio measurement.



: Reading holding.

**Single**

: Single trigger.

**Math**

: Enter math function configuration.

**Trig**

: Enter trigger function configuration.

**Meas**

: Enter parameter configuration of current measurement function.

**Menu**

: Relative system operations include storage, interface, command set, display, system information, etc.

**F1****F5**

: Redefine function.

### 1.3 Rear Panel

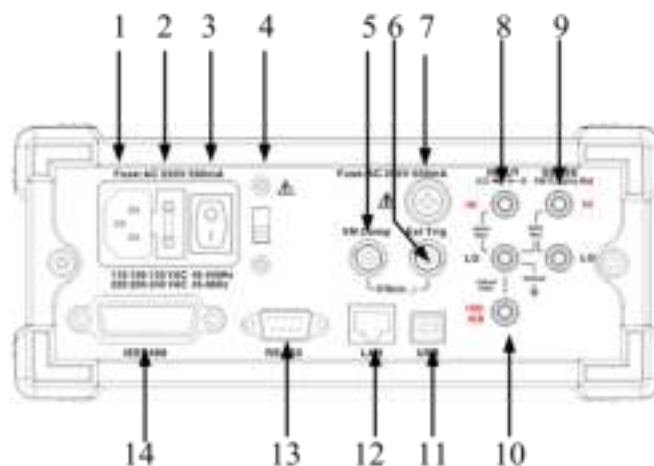

No.	Introduction
1	Power outlet.
2	Power fuses
3	Power switch
4	Voltage selector
5	VCM output (voltmeter completes measurement output)
6	External output
7	Current input fuse
8	HI and LO main input terminal
9	HI and LO sensor input terminal
10	Current input terminal
11	USB Device interface
12	LAN interface
13	RS232 interface
14	GPIB interface

Remark: Only terminals of No. 8, 9, 10 and 14 are used on “VICTOR 8165A”.

## 1.4 Adjust Handles

To adjust handles of digit multimeter, please hold the handles on both sides of the meter, and then rotate the handles to the needed positions. Operating method is as shown in the following figure

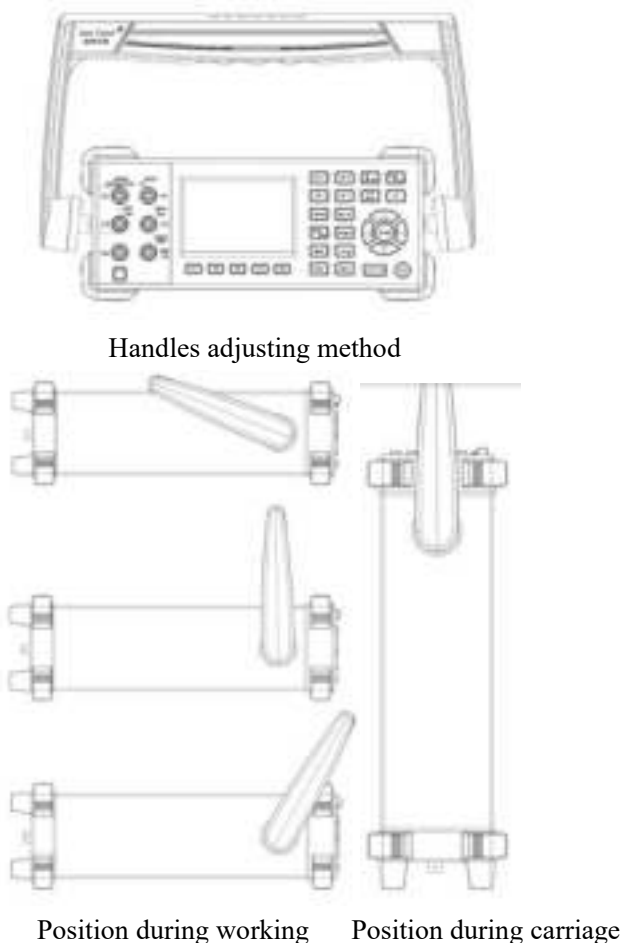

## 1.5 Start Multimeter

### 1. Connect to AC power

- 1) Power supply of multimeter may select 110V or 220V, and you may adjust power voltage selector installed on multimeter rear panel according to your power supply voltage.
- 2) Connect the multimeter to AC power with power line supplied by accessories.

### 2. Start multimeter

Turn on the power switch under power outlet.

### 3. If the instrument is not normally started, please check according to the following steps:

- 1) Check whether power line is well connected.
- 2) Check whether the power switch of rear panel is turned on.
- 3) If the instrument still can not be started after check, please check whether the power fuse is blown out, if necessary, replace fuses.
- 4) If the instrument still can not be started after check, please contact relevant departments.

## 1.6 User Interface

User interface has three kinds of display modes, and can switch among different modes by pressing the softkey of Display (显示).

Default user display interface:



Description: The figure displays the interface during AC voltage measurement, with major display being voltage measurement value, and auxiliary display frequency measurement value.

**Statistic data display interface:**



Statistic Data Display

Description: Under this display mode, besides current measurement values, the interface displays some statistic data, such as maximum value, minimum value, average value and standard deviation. At the bottom of the screen is the histogram composed of measurement data, showing data distribution.

History curve display interface:



History curve display

Description: Under this display mode, the upper part of the screen displays current measurement values, and the lower part displays tendency chart of the recorded data, wherein the abscissa axis represents number of measurement points, the first record value is 0 and increases by 1 every time gain a new measurement value; ordinate axis represents measurement value.

### 1.7 Measurement Wiring

Press **DCV** to select DC voltage measurement function.

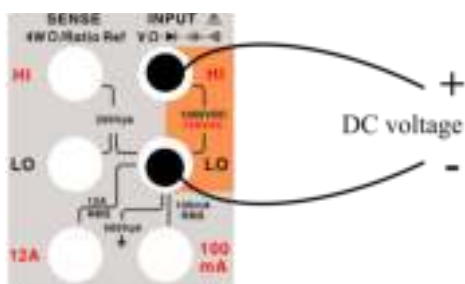

Press **Ratio** to select DC voltage ratio measurement function

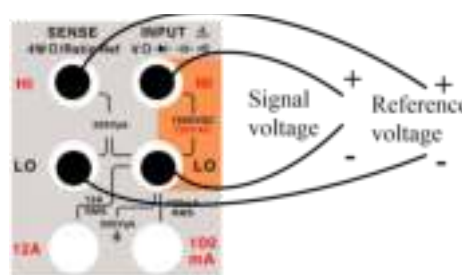

**Note:** The main input LO terminal and sense LO terminal of DC voltage ratio measurement function have to share common reference points, and their voltage difference can not exceed  $\pm 2V$ .

Press **ACV** to select AC voltage measurement function

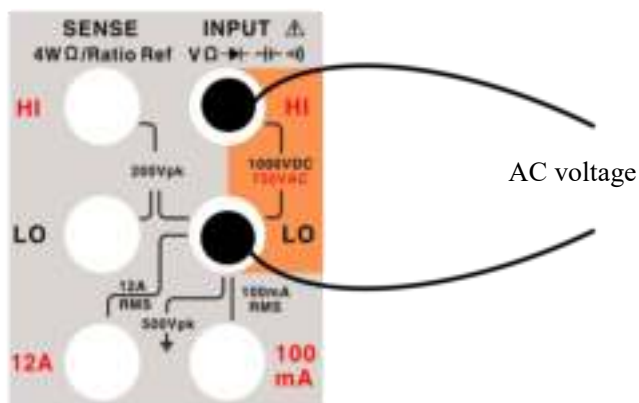

Press **DCI** to select DC current measurement function

1A-12A measurement is as shown in the following figure

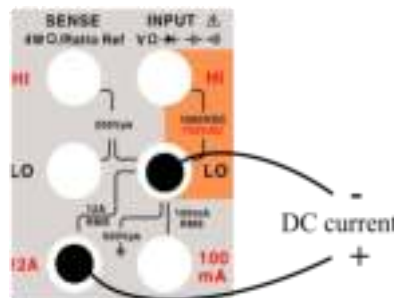
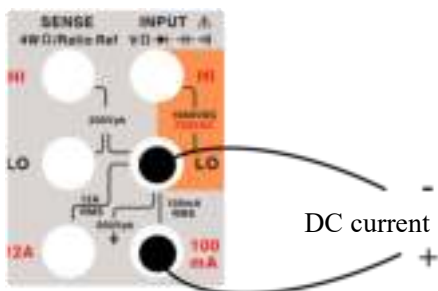

**Note:** 12A and 100mA input terminals are not allowed to be connected to the current measurement loops at the same time.

Press **ACI** to select AC current measurement function

100mA-12A measurement is as shown in the following figure:

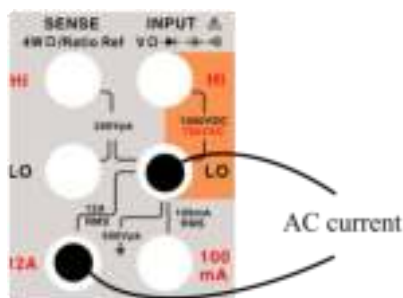
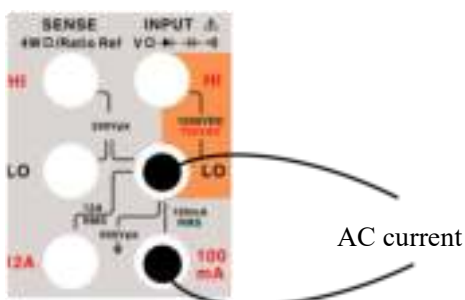

**Note:** 12A and 100mA input terminals are not allowed to be connected to the current measurement loops at the same time.

Press **2W 4W** to select 2-wire resistance measurement function

Press **2W 4W** to select 4-wire resistance measurement function

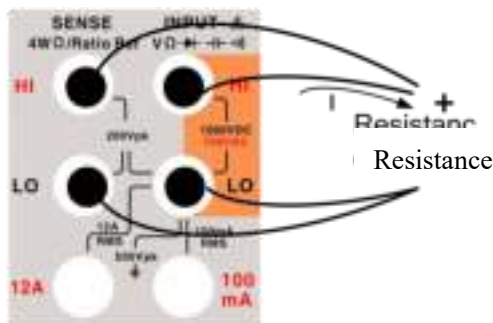
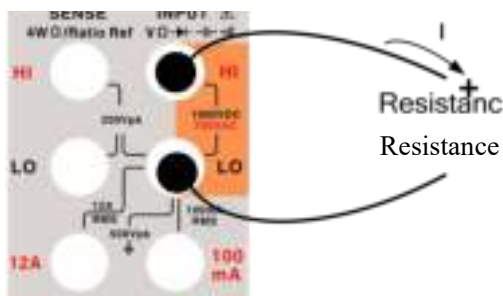

Press  to select frequency measurement function

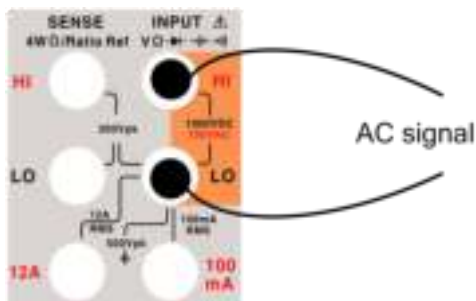

Press  to select period measurement function

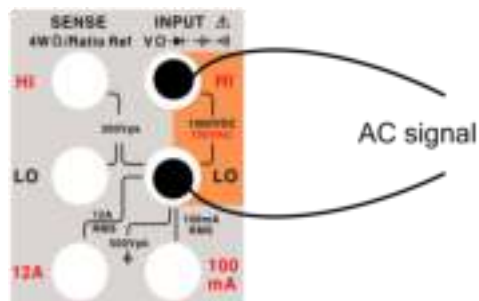

Press  to select capacitance measurement function.

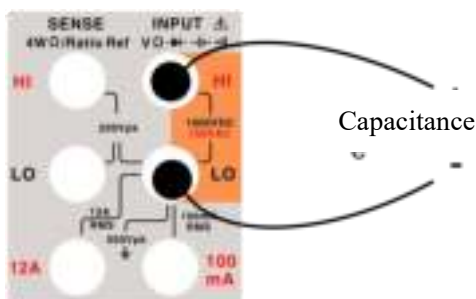

Press  to select continuity measurement function

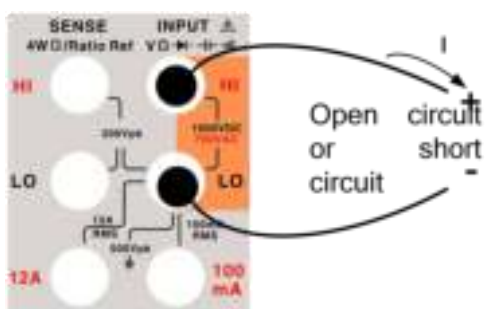

Press  to select diode test measurement function

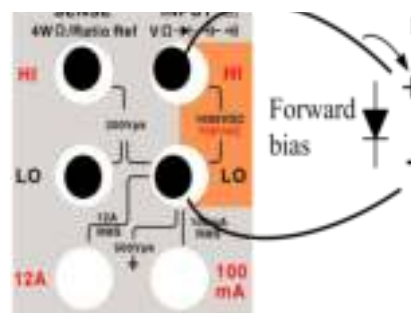

## 2. Basic Operations of Front Panel

### 2.1 Conduct Basic Measurement

#### 2.1.1 DC voltage measurement

##### Basic information









- Measurement range: 100mV, 1V, 10V, 100V and 1000V
- Maximum resolution: 100nV.

##### Operation description:

- 1) Press  to select DC voltage measurement function, and automatically enter DC voltage measurement function every time when the machine is started.



Description: Major display value refers to measured voltage value, and auxiliary displayed value refers to the ratio between current measurement value and full measurement range.

- 2) Connect test lines as indicated in chapter “1.4 Measurement wiring”.
- 3) Select measurement range as required, and may select automatic measurement, or press the softkeys of Measurement range+ (  ) and Measurement range- (  ) to select fixed measurement range, which have same effect as keys of  and  .
- 4) Press the softkey of Relative (  ) to record the current value, after which display the difference between actual measurement value and current recorded value.
- 5) Press the softkey of Display (  ) to switch modes, and refer to the chapter of **User interface** for details.
- 6) If necessary, press  to configure the following measurement parameters: integral time, input impedance and zero calibration method, and refer to the chapter of **Measurement configuration** for details.
- 7) If necessary, press  to configure math operation function (limits, dBm, dB and relative), and refer to description in the chapter of **Math operation** for details.

## 2.1.2 DC voltage ratio measurement

### Basic Information

- Ratio measurement refers to that measure input voltages to main input terminal and sense terminal with multimeter, and work out the ratio.  
Voltage ratio= Voltage value of main input terminal/Voltage value of sense terminal.
- Main input LO terminal and sense LO terminal have to share common reference points, and their voltage difference can not exceed  $\pm 2V$ .
- Ration measurement is automatic measurement range measurement, and automatic zero calibration is started. Main input terminal can measure up to 1000V voltage at most, and sense terminal to 12V voltage at most.

### Operation description





- 1) Press  to select DC voltage ratio measurement function.



Description: Major display represents the voltage ratio value between main input terminal and sense terminal, the lower part (IN) represents voltage value measured at main input terminal, and (REF) represents reference voltage value measured at sense terminal.

- 2) Connect test lines as indicated in the chapter of **1.4 Measurement wiring**.

- 3) Press  and  to select different integral times, and refer to the chapter of **Measurement configuration** for details

## 2.1.3 AC voltage measurement

### Basic information



- Measurement range: 100mV, 1V, 10V, 100V and 750V.
- AC technology: true virtual value measurement and AC coupling method.
- Maximum resolution: 100nV.

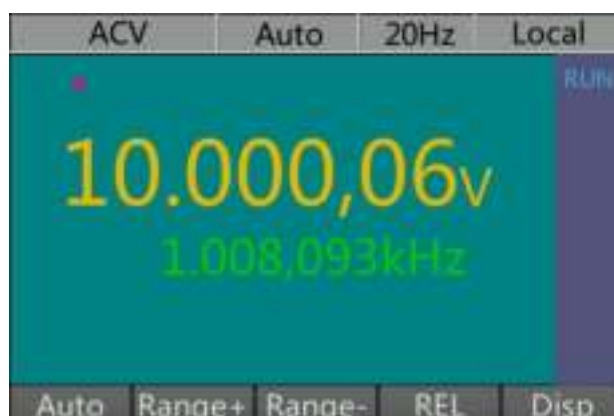

### Operation description

- 1) Press  to select AC voltage measurement function.





Description: Major displayed value refers to measurement voltage value, and auxiliary displayed value refers to frequency measurement value of the current input signal.

- 2) Connect test lines as indicated in the chapter of **1.4 Measurement wiring**.
- 3) Select measurement range as required, and may select automatic measurement, or press the softkeys of Measurement range+ () and Measurement range- () to select fixed

measurement range, which have same effect as keys of  and .

4) Press the softkey of Relative (  ) to record the current value, after which display the difference between actual measurement value and current recorded value.

5) Press the softkey of Display (  ) to switch modes, and refer to the chapter of “Users interface” for details.

6) If necessary, press  to configure the following measurement parameters: AC filter, and refer to the chapter of **Measurement configuration** for details.

7) If necessary, press  to configure math operation function (limits, dBm, dB and relative), and refer to description in the chapter of **Math operation** for details.

## 2.1.4 DC current measurement

### Basic information

- Current measurement is classified into low current measurement and high current measurement, with different wiring methods.
- Low current measurement range: 10uA, 100uA, 1mA, 10mA and 100mA
- High current measurement range: 1A and 12A.
- Maximum resolution: 10pA.





### Operation description

1) Press  to select DC current measurement function.



Description: Major displayed value refers to measurement current value, and auxiliary displayed value refers to the ratio between current measurement value and full measurement range.

2) Connect test lines as indicated in the chapter of **1.4 Measurement wiring**.

3) Select measurement range as required, and may select automatic measurement, press the softkey of  to select low current measurement, press the softkey of  to select high current measurement, and press keys of  and  to switch measurement range.

4) Press the softkey of Relative (  ) to record the current value, after which display the difference between actual measurement value and current recorded value.

5) Press the softkey of Display (  ) to switch modes, and refer to the chapter of **User**

**interface** for details.

6) If necessary, press  to configure the following measurement parameters: integral time, input impedance and zero calibration method, and refer to the chapter of **Measurement configuration** for details.

7) If necessary, press  to configure math operation function (limits, dBm, dB and relative), and refer to description in the chapter of **Math operation** for details.

## 2.1.5 AC current measurement

### Basic information

- Current measurement is classified into low current measurement and high current measurement, with different wiring methods.
- Low current measurement range: 100uA, 1mA, 10mA and 100mA
- High current measurement range: 1A and 12A.
- Maximum resolution: 100pA.





### Operation description

1) Press  to select AC current measurement function.





Description: Major displayed value refers to measurement current value, and auxiliary displayed value refers to frequency measurement value of the current input signal.

2) Connect test lines as indicated in the chapter of **1.4 Measurement wiring**.

3) Select measurement range as required, and may select automatic measurement, press the softkey of  to select low current measurement, press the softkey of  to select high current measurement, and press keys of  and  to switch measurement range.

4) Press the softkey of Relative (  ) to record the current value, after which display the difference between actual measurement value and current recorded value.

5) Press the softkey of Display (  ) to switch modes, and refer to the chapter of **Users interface** for details.

6) If necessary, press  to configure the following measurement parameters: AC filter and refer to the chapter of **Measurement configuration** for details.

7) If necessary, press  to configure math operation function (limits and relative), and refer to description in the chapter of **Math operation** for details.

## 2.1.6 Resistance measurement

### Basic information

- 10Ω, 100Ω, 1kΩ, 10kΩ, 100kΩ, 1MΩ, 10MΩ, 100MΩ and 1GΩ.
- Maximum resolution: 10uΩ.



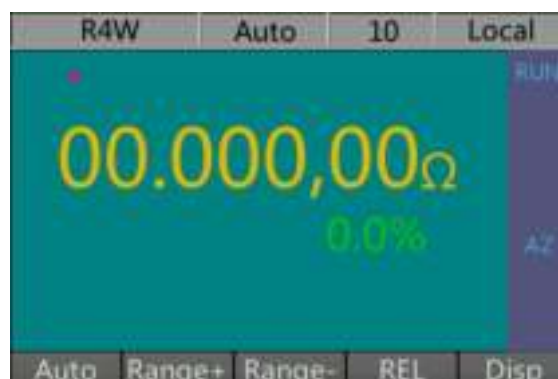

### Operation description

1) Press  to select 2-wire resistance measurement or 4-wire resistance measurement function.





Description: Major displayed value refers to measurement voltage value, and auxiliary displayed value refers to the ratio between the current measurement value and full measurement range.

2) Connect test lines as indicated in the chapter of **1.4 Measurement wiring**.

3) Select measurement range as required, and may select automatic measurement, or press the softkeys of Measurement range+ (  ) and Measurement range- (  ) to select fixed measurement range, which have same effect as keys of  and .

4) Press the softkey of Relative (  ) to record the current value, after which display the difference between actual measurement value and current recorded value.

5) Press the softkey of Display (  ) to switch modes, and refer to the chapter of **User interface** for details.

6) If necessary, press  to configure the following measurement parameters: integral time and zero calibration and refer to the chapter of **Measurement configuration** for details. Start automatic zero calibration during 4-wire resistance measurement.

7) If necessary, press  to configure math operation function (limits and relative), and refer to description in the chapter of **Math operation** for details.

### Leads resistance eliminating method for two-wire resistance measurement:

1. Connect one end of test lead to multimeter, and short together with probe end.
2. Press the softkey of Relative (  ) to make zero, and every resistance measurement will reduce current lead resistance measurement value.
3. Connect test probe end to test circuit, and measure resistance value.

## 2.1.7 Frequency/Period measurement

### Basic information





- Frequency measurement band: 3Hz to 300 kHz.
- Period measurement band: 3.3us to 0.33s
- Measurement range: 100mV, 1V, 10V, 100V and 750V
- Input signal range: 100mVAC to 750VAC.
- Technology: equal precision.

### Operation description:

- 1) Press  to select frequency measurement function or period measurement function.





Description: During frequency or period measurement, auxiliary display refers to virtual value of AC voltage of input signal.

- 2) Connect test lines as indicated in the chapter of **1.4 Measurement wiring**.
- 3) Select measurement range as required, and may select automatic measurement, or press the softkeys of Measurement range+ (  ) and Measurement range- (  ) to select fixed measurement range, which have same effect as keys of  and  .
- 4) Press the softkey of Relative (  ) to record the current value, after which display the

difference between actual measurement value and current recorded value.

5) Press the softkey of Display (显示) to switch modes, and refer to the chapter of **Users interface** for details.

6) If necessary, press  to configure the following measurement parameter, that is gate time, and refer to the chapter of **Measurement configuration** for details.

7) If necessary, press  to configure math operation function (limits and relative), and refer to description in the chapter of **Math operation** for details.

## 2.1.8 Capacitance measurement

### Basic information

- Measurement range: 1nF, 10nF, 100nF, 1uF, 10uF, 100uF, 1mF, 10mF and 100mF.
- Maximum resolution: 10pF.



### Operation description

1) Press  to select capacitance measurement function.



Description: Major displayed value refers to measurement capacitance value, and auxiliary displayed value refers to the ratio between the measurement value and full measurement range.

3) Connect test lines as indicated in the chapter of **1.4 Measurement wiring**.

4) Select measurement range as required, and may select automatic measurement, or press the softkeys of Measurement range+ (量程+) and Measurement range- (量程-) to select fixed measurement range, which have same effect as keys of  and .

5) Press the softkey of Relative (相对) to record the current value, after which display the difference between actual measurement value and current recorded value.

6) Press the softkey of Display (显示) to switch modes, and refer to the chapter of **Users interface** for details.

7) If necessary, press  to configure math operation function (limits and relative), and refer to description in the chapter of **Math operation** for details.

### Test leads capacitance eliminating method:

1. Plug out the probe end of positive lead out from test circuit, and keep it open.
2. Press **Relative** to make zero.

3. Re-connect the probe end of positive lead to test circuit, and measure capacitance value.

## 2.1.9 Continuity measurement

### Basic information

- Test power source: 1mA.
- Beeper threshold: 1Ω-1000Ω is available, and 10Ω as a default.

### Operation description

- 1) Press  to select continuity measurement function.

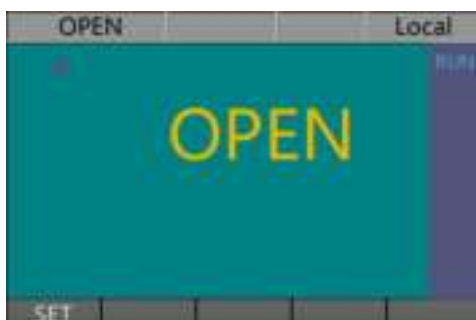

Description: When the measured resistance value is larger than the beeper threshold, display **OPEN**, and when the measured resistance value is smaller than the beeper threshold, display resistance value.

- 2) Connect test lines as indicated in the chapter of “1.4 Measurement wiring”.
- 3) Press the softkey of Setup (設置) to set beeper threshold: when the measured resistance is lower than beeper threshold, the beeper beeps, and the beeper threshold can be set as 1Ω-1000Ω, with 10Ω being a default.

## 2.1.10 Diode measurement

### Basic information

- Test current source: 1mA.
- Beeper threshold:  $0.3V \cong \text{test voltage} \cong 3V$ , non-adjustable.

### Operation description

1. Press  to select diode measurement function.



Description: When voltage value is higher than measurement threshold, display **OPEN**, otherwise display voltage value.

2. Connect test lines as indicated in the chapter of **1.4 Measurement wiring**.

## 2.2 Usage of Sensor

### 2.2.1 Thermal resistance sensor







Thermal resistance sensor refers to sensor converting temperature into resistance, and currently scale dividing symbols of Pt100 and Pt1000 have been preset.

1. Press  to select sensor measurement function



24

Description: Major displayed value refers to temperature value, and auxiliary displayed value refers to corresponding resistance value.

2. According to sensor type, connect test lines as indicated in the chapter of **1.4 Measurement wiring**, and RTD wiring method is the same as that of resistance measurement.
3. Select scale dividing symbols as is required, press the softkeys of Graduation mark + () and Graduation mark - () or keys of  and .
4. Press the softkey of Relative () to record the current value, after which display the difference between actual measurement value and current recorded value.
5. Press the softkey of Display () to switch modes, and refer to the chapter of **User interface** for details.

## 3. Characteristic and Function

### 3.1 Measurement Configuration

In this section, we will provide materials necessary to configure multimeter and execute measurement. You may never need to change any of the hereby mentioned measurement parameters; however we still provide them for you to refer to at any time.

#### 3.1.1 AC signal filter



The multimeter has three different AC filters which can optimize low-frequency accuracy or minimize AC stability time, and can select filters of low speed, mid speed or high speed



according to the input signal frequency.







AC filter is limited to be used in AC voltage and AC current measurement.

Input Frequency	Selected AC filter	Reading Stability Time
3Hz to 300kHz	Low-speed filter	7 seconds
20Hz to 300kHz	Mid-speed filter (default value)	1 second
200Hz to 300kHz	High-speed filter	0.10 second

- AC filter selection is stored in volatile memory, and after cutting off power or resetting remote interface, multimeter will select mid-speed filter (20Hz).
- During front panel operation, ensure that the current measurement is ACV or ACI, after pressing , press the softkey of Filter (滤波), and select low-speed filter (3Hz), mid-speed filter (20Hz) and high-speed filter (200Hz) through  and , among which mid-speed filter is default option.

### 3.1.2 Continuity threshold resistance

When measuring continuity measurement, and if measurement resistance is smaller than threshold resistance, multimeter will send out a continuous individual tone. Threshold resistance value can be set as any number from 1Ω to 1000Ω, which can only be adjusted on the front panel.





- Threshold resistance is stored in volatile memory, and after cutting off power or resetting remote interface, multimeter will reelect 10Ω.
- Threshold resistance is set as 10Ω when multimeter leaves factory.
- After starting continuity function, press the softkey of Setup (设置), and press up, down, right and left keys and the ENTER key
-  And  can move the movable and flashing cursor to the position specified by you, and  and  can edit value size of the current position, with  meaning increasing and  decreasing.

### 3.1.3 DC input resistance

Generally, multimeter input resistances at all DC voltage shifts are all set as 10MΩ to lower noise, and if you want to reduce the effect caused by measurement load error, set the input resistance at 100mVdc, 1Vdc and 10Vdc shifts more than 10GΩ.

DC input resistance is restricted to be used only in DC voltage measurement.

	Input Resistance Measurement Ranges of 100mV, 1V and 10V	Input Resistance Measurement ranges of 10V and 1000V
Fixed Resistance ON (default value)	10MΩ	10MΩ
Fixed Resistance OFF	>10GΩ	10MΩ

- Input resistance setting is stored in volatile memory, and after cutting off power or resetting remote interface, multimeter will reelect  $10\Omega$  (including all the DC voltage shifts).
- Front panel operation: After starting DC voltage measurement function, press , then the softkey of Impedance () , and  and  to input resistance, and then press  key. Default value is  $10M\Omega$ .

### 3.1.4 Resolution



Resolution is expressed by digits which can be measured or displayed by multimeter, which can be set as 4, 5 or 6 integrated digits, and add [1/2] single units represented by [0] or [1]. If it is expected to increase measurement accuracy or control noise, please select 6 1/2 digits, while to increase measurement speed, please select 4 1/2 digits.





Resolution setting is suitable for all the measurement functions. Resolution of math operation (zero-digit value, limits, dB, dBm and limit test) is the same as that of measurement function.

Corresponding relation between resolution digit and integral time (within power period) is as follows:

Resolution	Integral Time
High speed 4 1/2	0.02 PLC
Low speed 4 1/2	0.1PLC
High speed 5 1/2	0.2PLC
Low speed 5 1/2	1PLC
High speed 6 1/2	2PLC
Mid speed 6 1/2	10PLC
Low speed 6 1/2	100PLC

- Resolution is stored in volatile memory, and after cutting off power or resetting remote interface, multimeter will set resolutions of all the measurement functions as mid speed 6 1/2.
- During DC continuity and diode test, resolution is fixed as high speed 5 1/2.
- During DC and resistance measurement, change of resolution digit number does not only change multimeter resolution, but also integral time, namely, during one certain measurement, input signal period in sampling of simulation/digit converter (A/D Converter) on multimeter. Meanwhile, please refer to the chapter of [Integral Time].
- During AC measurement, actually resolutions are all fixed as 6 1/2 digits.
- During ratio measurement, resolution refers to the resolution of receiving signals at input terminal.
- During front panel operation, there are two methods to change resolution.





1. During measurement function, keys of  and  can change resolution.

2. After pressing , press the softkey of Integral () , select different integral times through keys of  and  , and then press .

### 3.1.5 Integral time

Integral time refers to the period to input signals in sampling of simulation/digit converter (A/D Converter) on multimeter during measurement, which may influence measurement resolution (if it is expected to gain better, it may be set longer integral time) and measurement speed (if it is expected to gain faster measurement, it may be set shorter integral time).

Integral time setting is only suitable for all the measurement functions exclusive of AC voltage, AC current, frequency and period. The integral time of math operation (zero digit, limits, dB dBm and limit test) is the same as that of the used measurement functions.

- Integral time is expressed by power period number (NPLC), for which 0.02, 0.1, 0.2, 1, 2, 10 and 100 power periods are available. Its default value is 10 power periods.
- Integral time is stored in volatile memory, and after cutting off power or resetting interface, multimeter will select 10PLC as the integral time.
- Only the power periods in integer (1, 10 or 100PLC) provide normal mode (power frequency noise) control.
- Front panel operation: 1. During selection of resolution digit, it may indirectly set integral time. 2. After pressing , press the softkey of Integral (积分), select different integral times through keys of  and , and then press .

### 3.1.6 Switch between front/rear input terminals



All the measurement conducted by input terminal can also be conducted by input terminal on rear terminal (except 1A and 10A current measurement). It only needs to press the front and rear input terminal switch to switch between front and rear input terminals.

- After selecting the input terminal on rear panel, the **Rear** operation indicator will be on.
- After selecting the input terminal on front panel, the **Front** operation indicator will be on.

### 3.1.7 Auto zero calibration

When auto zero calibration is started (default method), inside of multimeter will make input signal, measure circuit separate, take a zero-input reading, and minus the foregoing reading by the zero-input reading after each measurement. Thus it can avoid bias voltage on input circuit of multimeter which will influence accuracy.







Auto zero calibration function is only suitable for DC voltage, DC current and two-wire resistance measurement, and when selecting four-wire resistance measurement or ratio measurement, auto zero calibration function will start automatically.

- Auto zero calibration method is stored in volatile memory, and after cutting off power or resetting remote interface, multimeter will automatically start auto zero calibration function.
- Front panel operation: Under measurement function, after pressing , then press the softkey of Zero calibration (校零), select ON or OFF through  and , and then press



### 3.1.8 Select measurement range (measurement shift)

You may use auto measurement range function to make multimeter select measurement range by itself, or use manual measurement range function to select fixed measurement range. Auto measurement range function is quite convenient, for multimeter will automatically select measurement range proper for every measurement. However, manual measurement range function may accelerate measurement, for multimeter does not need to take time to determine measurement range for every measurement.

- The selected shift-selecting method (auto or manual) is stored in volatile memory, and after cutting off power or resetting remote interface, multimeter will go back to auto measurement range method.
- Auto measurement range threshold value: low-end measurement range refers to measurement range <10%; high-end measurement range refers to measurement range >120%.
- If input signal is larger than currently measurable measurement range, multimeter will send out overloading indication, **over measurement range** appearing on front panel.
- During frequency and period measurement, multimeter only uses one measurement range to include all the input signals from 3Hz to 300 kHz.
- During continuity test, measurement range is fixed as 1K $\Omega$ , and during diode test, measurement range is automatic (1Vdc or 10Vdc) and current source output is 1mA.
- During ratio measurement, the specified measurement is suitable for input terminal signal, and when measuring sense terminal reference voltage, multimeter will automatically select auto measurement range function.
- Front panel operation: Under measurement function: 1. It can enter manual measurement range mode through  and ,  referring to high measurement range and  referring to low measurement range. 2. It can also enter manual measurement mode by pressing softkeys of Measurement range (  ) + and Measurement range - (  ) 3. Press the softkey of Auto (  ) to select auto measurement range.

### 3.2 Math Operation

Math operation function means to conduct math operation to each reading or series of stored reading data. The selected math function keeps valid until power is cut off.

Under measurement function, press the softkey of Display (  ) to display related math measurement values under the current function, which is as shown in the following figure.



Description:

- Current value refers to measurement value under the current function
- Samples refer to sum of measurement values collected till now after confirming that one certain measurement function collects the first number.
- Maximum value is the maximum value among all the existing sampling values.
- Minimum value is the minimum value among all the existing sampling values.
- Average value refers to the average value of all the existing sampling values.
- Standard deviation refers to the standard deviation of all the existing sampling values.
- dBm: dBm is a logarithm expression, which is gained according to the contrast between the power imposed to reference resistance and 1mV.  $\text{dBm} = 10 \times \log_{10} (\text{reading}^2 / \text{reference resistance} / 1\text{mW})$ .
- dB: dB measurement refers to the difference between input signal and existing relative value (the two are both converted to dBm).  $\text{dB} = \text{reading in dBm} - \text{relative value in dBm}$ .

The following table shows possible combination between math operation function and measurement function, wherein each ● represents one possible combination. If the selected math operation can not be executed in the current measurement, the math operation function will be automatically called off.

	Voltage		Current		resistance		Frequency	Period	Continuity	Diode	Ratio	Temperature
	DC	AC	DC	AC	Two-wire	Four-wire						
Relative	●	●	●	●	●	●	●	●				●
Limit	●	●	●	●	●	●	●	●				●
dB	●	●										
dBm	●	●									●	

### 3.2.1 Relative (zero) operation

When starting relative operation, the reading displayed on screen is the difference between actual measurement value and **relative value**.

$$\text{Reading value} = \text{actual measurement value} - \text{relative value}$$



One of the relative measurement applications is to counteract test lead resistance to gain more accurate two-wire resistance measurement.

Relative operation is suitable in all the measurement functions exclusive of continuity, diode and ratio measurements.

Preset value can be adjusted and set as any value from 0 to 120% of the highest measurement range in the current function, which is stored in volatile memory, and after cutting off power or resetting remote interface or changing measurement function, the zero-digit value will be cleared out.

There are two methods to configure **preset value** of relative operation.

1) In basic measurement interface, press the softkey of Relative (相对), and multimeter will automatically set the current measurement result as the **preset value**.

2) On basic measurement interface, press  →  (Relative) to enter “Relative value” setting interface where edit **relative value** through direction keys, and unit is determined by the current measurement function.



Press the softkey of Current value (当前值) to set the **Relative value** as the current reading.

Press the softkey of Default (默认值) to reset the **Relative value** to 0.

Press softkeys of On/Off (打开/关闭) to start or stop relative operation, and after starting, **Relative** indication can be seen on the right side of main interface.



After setting, press the softkey of Exit (退出) to go back to the former-layer interface.

### 3.2.2 dBm value measurement

dBm function is a logarithm expression, which is gained according to the contrast between the power imposed to reference resistance and 1mV, and dBm measurement is only suitable for DC voltage measurement and AC voltage measurement.

$$\text{dBm} = 10 \times \log_{10} (\text{reading}^2 / \text{reference resistance} / 1\text{mW}).$$

Reference resistance can be any value from 2Ω-8000Ω, which is set as 600Ω when leaving the factory. Reference resistance value is stored in volatile memory, which will be cleared out after cutting off power, resetting remote interface or changing measurement function.

Modify reference resistance value: Press  →  to enter setting interface, and press direction keys to input needed reference resistance value, after which press .

### 3.2.3 dB value measurement.

Each dB measurement value refers to the difference between input signal and the stored relative

value which have been converted to dBm values. dB value measurement is only suitable for DC voltage measurement and AC voltage measurement.

$$\text{dB value} = \text{dBm value of readings} - \text{dBm value of relative values.}$$

Relative value can be adjusted and set as any value from -120dBm to 120dBm, which is stored in volatile memory and will be cleared out after cutting off power, resetting remote interface or changing measurement function.

Modify reference resistance value: Press  →  to enter setting interface, and edit relative value through direction keys.

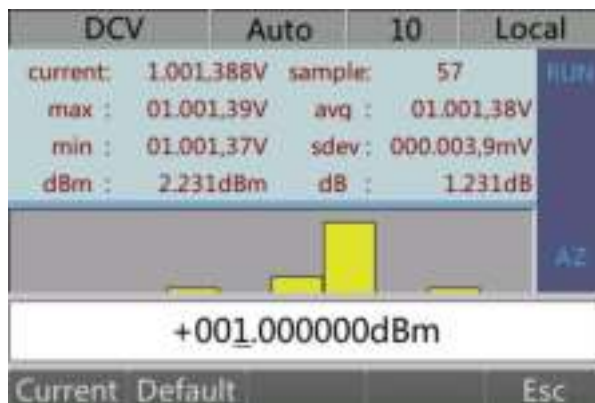

Press the softkey of Current value () to set the **Preset value** as the current reading.

Press the softkey of Default () to reset the **Relative value** to 0.

After setting, press the softkey of Exit () to go back to the former-layer interface.

### 3.2.4 Limit test

Limit test function can be used to test whether it exceeds/does not exceed the specified upper or lower limit, indicate signals passing or failing test (screen display + beeping), and can output negative pulse through RS232 serial port on instrument rear panel. If the measured reading is within the specified limited range, multimeter will output a negative pulse on the pin 1; while it exceeds the upper or lower limit, multimeter will output a negative pulse on the pin 9.

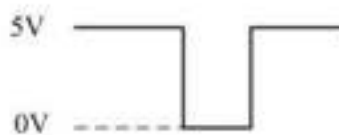

- ① Passing output
- ⑤ Common terminal
- ⑨ Not passing output

Negative pulse

- Upper and lower limit can be set as any value from 0 to 120% of the highest measurement range in the current function.
- The upper and lower limit values are stored in temporary memory, and after multimeter cuts

off power, the upper limit value will be set as 1 and lower limit value as 0.

In configuration limit test, press  (Limit) to enter setting interface, and edit values through direction keys.



Press the softkey of Upper limit () to set upper limit value.

Press the softkey of Lower limit () to set lower limit value.

Press softkey of On/Off () to start or stop limit operation. After starting, limit test status indication can be seen in the right side of main interface, with **Pass** meaning that the measured value does not exceed the specified upper or lower limit, with **Excessively higher** meaning exceed the specified upper limit and **Excessively lower** meaning exceed the specified lower limit. When status switches from **Pass** to **Excessively higher** or **Excessively lower**, the beeper will beep one time.

After setting, press the softkey of Exit () to go back to the former-layer interface.

### 3.3 Trigger

VICTOR 8165A and VICTOR 8165 provide many trigger methods, including auto, single and external. Multimeter can read one reading or readings in specified number (up to 50,000) every time it receives a trigger signal, and can set the delay time between trigger and readings.

In measurement interface, press  to enter the trigger configuration interface indicated in the following figure.



Press the softkey of Trigger source () to set auto, single or external trigger.



Press the softkey of Remain (保持) to set sensitivity range of reading holding function.

Press the softkey of Setup (设置) to set related trigger parameters, such as samples and trigger delay.

Press the softkey of Output (输出) to start or stop trigger output.

### 3.3.1 Selection of trigger source

You have to specify the trigger source of the trigger signal which will be received by multimeter. Multimeter can receive single trigger through front panel and hardware trigger at Ext Trig end or continuously take readings through auto trigger, and adopt auto trigger when the power is connected. \* (Sampling) Indicator will be lighted on in every measurement. The trigger source is stored in volatile memory, and will be set as auto trigger (front panel) after cutting off power or resetting remote interface.

#### Auto trigger:

When the trigger source is set as auto trigger, the **Operation** indicator in status column lights on, and multimeter will gain continuous readings in the fastest speed allowable in the current configuration. At this time if press down , it will start reading holding function, and can capture and keep a stable reading on screen.

#### Single trigger:

When the trigger source is set as auto trigger, the **Single** indicator in status column will light on, and multimeter will capture one reading or readings in specified number every time the key of  is pressed down.

#### External trigger:

When the trigger source is set as auto trigger, the **External** indicator in status column will light on, and multimeter will receive the hardware trigger at the Ext Trig end on rear panel.

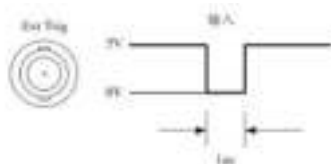

Every time there is negative pulse at **Ext Trig** end, multimeter will gain one reading or readings in specified number (sampling counting).

**Hint:** In remote mode, multimeter can switch to local mode after pressing .

### 3.3.2 Reading holding



It can capture and hold stable readings on the front panel display by using reading holding mode which is quite useful when you move away probe after collecting one reading and want to hold the reading on the screen.



Reading holding is only suitable for front panel operation, which will be neglected by multimeter in remote operation.

There is an adjustable sensitivity range in reading holding function, which is used to determine whether the reading is sufficiently stable and can be displayed, and is expressed by percentage ratio of the current reading. Only if three continuous readings are all within selected sensitivity range, can multimeter capture and display new readings.



The sensitivity range is one of the following values, including 0.01% and 0.1% (default value), 1.00% or 10.00% of the reading. For example, if you select 1.00% range, input signal of multimeter is 5.000V, and only if three continuous readings are all from 4.975 to 5.025, can multimeter capture and display new readings.

What calls for special attention is that if the new reading is within the sensitivity range of the current displayed value, multimeter will not update displayed value even though it is determined as stable reading. For example, the current displayed value is 5.000V, and the next continuous three measurements are all 5.498V, the screen still displays 5.000V.

In measurement status, press  to start holding function, **Holding** indicator in status column lights on, and press  to stop holding function.

If it is expected to modify sensitivity range, press    (Remain) to enter setting interface to select needed sensitivity.

### 3.3.3 Trigger parameter setting

Press    (Setup) to enter trigger parameter setting interface to set samples and trigger delay.

#### Samples:

Every time multimeter receives trigger signal, it will read readings in specified number.

The selected samples are stored in volatile memory, and multimeter will set the samples as 1 after cutting off power or resetting remote interface.

Press the softkey of Number () to set samples, wherein setting range is from 1 to 50000 and default value is 1.



#### Delay:

You can add delay time to trigger signal and each sample behind it, which is quite useful to settle down input signal or adjust interval between a series of readings and other applications before you want to capture readings.

- Trigger delay time is stored in volatile memory, and multimeter will select auto trigger delay after cutting off power or resetting remote interface. Default value is 0.
- If you select non-auto setting status, the delay time will be suitable for all the measurement functions and measurement ranges.
- If multimeter is configured to capture more than one readings in every trigger, the trigger delay time specified by you will be inserted between trigger signal and each reading.

Press the softkey of Delay () to enter delay configuration setting interface, and modify values and unit through direction keys. Setting range is from 1 to 3600s, and default value is 0.

### 3.3.4 Trigger output

Press    (Output) to enter configuration interface of trigger output function, and you can select to start or stop.

When opening, VM Comp (Voltmeter Complete Terminal) on rear panel will provide a negative pulse every time each measurement is completed. Voltmeter completer signal and external trigger signal can realize standard hardware exchange (Hand Shake) sequence between measurement device and switch device.

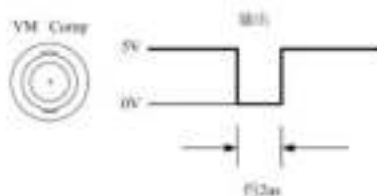



### 3.4 Data Record

Data record function of VICTOR 8165A and 8165 provides a front-panel user interface to make it possible for you to check history data without connecting to a computer.

When switching functions or power failing, data record will be cleared out, and if necessary, please save the record into USB drive.

When the USB interface on front panel is connected to USB drive, it can save history data to the measRecords folder under USB drive's root directory, with the measurement data being csv file which is named by current function name plus serial number, such as DCV-1.csv.

Press   (History) to enter history data interface, and scan data through direction keys, which is as shown in the following:

Program	DCV		
Range	auto		
Count	89		
Max	000.004,3mV		
Min	000.002,8mV		
Avg	000.003,4mV		
Sdev	000.000,3mV		
1	+4.268909e-06	2	+4.049534e-06
3	+4.164030e-06	4	+4.178377e-06
Update ToUdisk			

Press the softkey of Update () to refresh historic data.

Press the softkey of Store in U disk () to save the data into USB drive as csv file, when it is necessary to set file name.

The file is named by current function name plus serial number, wherein function name is automatically set by system and you just need to set serial number through direction keys, and

then press .

## 3.5 Relevant System Operations

### 3.5.1 System setting

Press  →  to set system.

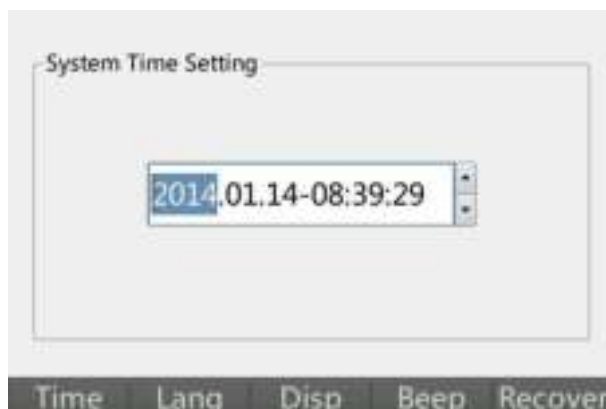

Press the softkey of Time () to set system time.

Press the softkey of **Lang** to switch display languages on interface.



Press the softkey of Screen () to set screen brightness.

Press the softkey of Buzzer () to start or stop beeper output.



Press the softkey of Recover () to restore to factory setting.

### 3.5.2 Command set

VICTOR 8165A and 8165 are compatible with command sets of Agilent 34401A, Agilent 34410A and Fluke45.

Press the key of  →  (Command set) to select all the command sets.

### 3.5.3 Topic

Press  →  (Topic) to modify system interface style.

### 3.5.4 Self-test

VICTOR 8165A and 8165 can conduct self-test to hardware system, and output the test result on the screen.

Press  →  →  (Self-test---Start) for self-test.

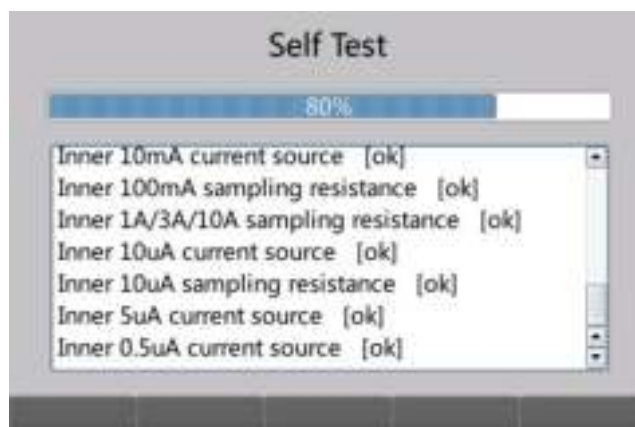



### 3.5.5 Calibration

**Only qualified professionals can conduct multimeter calibration, and incorrect usage of calibration function may cause to incorrect multimeter measurement.**



Refer to *VICTOR 8165A and 8165 Calibration Manual* for specific calibration details.

### 3.5.6 System information inquiry and system updating

VICTOR 8165A and 8165 support users to update software systems, and in case of users finding system BUG or needing to add functions, contact after-sales service, and we will serve for system updating.

Press the key of  →  (system information) to inquire current system information, such as serial number and software version number.

Before system updating, it is necessary to make following preparations: contact after-sales service to gain a needed software update package, prepare a USB drive, establish updatefile folder under the root directory, copy the software update package to this folder, and plug the USB driver into the USB interface on multimeter front panel.

Press the key of  +  (System update) after all the preparations to update the system.

## 4. Conduct Remote Control

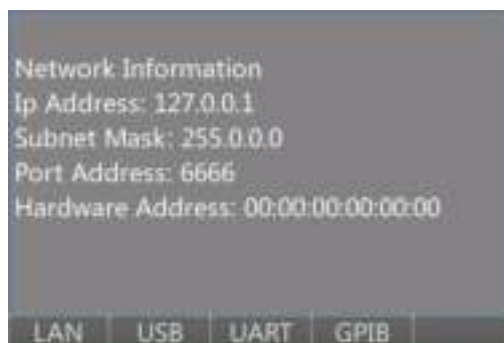

You can conduct remote control to this instrument which supports GPIB, RS232, USB and LAN interfaces. This chapter introduces how to conduct corresponding configuration. Refer to *VICTOR 8165A Digit Multimeter Programming Manual* for remote interface commands.

To configure interface, press  →  (Interface) to enter interface setting page.



Press the softkey of  to inquire current LAN information, and re-press  to configure LAN parameters.

Press the softkey of  to inquire USB information, and there are no configurable options for USB.

Press the softkey of  to inquire current serial port information, and re-press  to configure serial port parameters including Baud rate and check digit.

Press the softkey of  to configure GPIB interface address.

### 4.1 GPIB Interface Configuration (Only Supported By 8165A)

Equipment on **GPIB (IEEE-488)** interface has to be equipped with an exclusive address. You can set the multimeter address as any integral value from 0 to 30, with the factory-leaving address being **22**.

Computer **GPIB** interface card has its own address, and make sure that all the instruments on interface bus do not use this address.

GPIB address is stored in non-volatile memory, and can not be changed after power-off, factory reset (\*RST) or instrument presetting (**SYSTEM: PRESet**).

## 4.2 RS232 Interface Configuration

RS232 communication needs to be configured with Baud rate and check digit.

In RS232 setting interface,

Press the softkey of Baud rate (  ) to set the Baud rate as 1200, 2400, 4800, 9600, 14,400, 19,200, 38,400, 56,000, 57,600, 115,200, 128,000 and 256,000, with 115,200 as default. The current selection is stored in non-volatile memory.

Press the softkey of check digit (  ) to set the check digit as non-check, odd parity check or even parity check, with non-check as default.

Baud rate and check digit are stored in non-volatile memory, and can not be changed after power-off, factory reset (\*RST) or instrument presetting (**SYSTEM: PRESet**).

## 4.3 USB Interface Configuration

USB interface does not need configuration parameters to set multimeter, and connect multimeter to computer USB terminal. Pay attention to that computer might need several seconds to identify and establish connection with multimeter.

## 4.4 LAN Interface Configuration

When using **LAN** interface communication, it is necessary to correctly configure **IP** address, subnet mask and gateway, after which it can communicate normally.

**IP address:** All the IP and TCP/IP communications of instrument all need internet protocol (IP) address. The equipment IP address needs to be manually set.

Factory default IP address configuration is: 192.168.1.230.

**Subnet mask:** multimeter determines whether a customer's IP address is on the same local subnet through subnet mask, and if the customer's IP address is on other subnets, it is necessary to send all the software packages to the default gateway.

Factory default subnet mask configuration is: 255.255.255.0.

**Default gateway:** default gateway address allows multimeter to communicate with systems on non-local subnets. Therefore, when the software package is sent to equipment which is on non-local subnet, use this default gateway confirmed by subnet mask setting.

Factory default subnet mask configuration is: 192.168.1.1.

LAN interface configuration parameters are stored in non-volatile memory, and can not be changed after power-off, factory reset or instrument presetting (**SYSTEM: PRESet**).

## 5. Measurement Guide

### 5.1 DC Measurement Considerations

#### 5.1.1 Thermoelectromotive force error

Thermal voltage is the most common error source in low-level DC voltage measurement, which will be caused when you use heterogeneous metals to connect circuit under different temperatures. And each joint between each metal will produce a thermocouple and a voltage proportionable to the joint temperature. You have to take necessary precaution measures to reduce thermocouple voltage and temperature change during low-level voltage measurement. And the best connecting method is copper-copper crimping, for the multimeter input terminal is made from red copper. The following table lists common thermal voltage during heterogeneous metal connection.

Copper With	mV / °C (approximate value)	Copper With	mV / °C (approximate value)
Welding of cadmium and stannum	0.2	Aluminum	5
Copper	<0.3	Welding of stannum and plumbum	5
Gold	0.5	Kovaralloy or alloy	40
Silver	0.5	Silicon	500
Brass	3	Copper oxide	1000
Beryllium copper	5		

#### 5.1.2 DCV load error

If resistance of the equipment under test approximates multimeter internal resistance, it will cause measurement load error which is listed in the following figure.

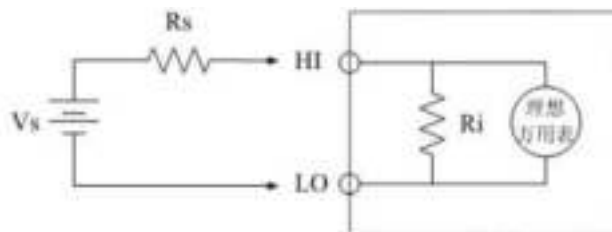

$V_s$ =Ideal voltage under test

$R_s$ =Resistance of voltage source under test

$R_i$ =Multimeter input resistance ( $10M\Omega$  or  $>10G\Omega$ )

$$\text{Error (\%)} = \frac{I_{00} \cdot R_s}{R_s + R_i}$$

In order to reduce load error influence and the pickup noise to the minimum extent, it is needed to set the multimeter input resistance  $>10G\Omega$  during the measurement of 100mV, 1V and 10V measurement range. For 100V and 1000V measurement ranges, input resistance is fixed as 10M $\Omega$ .

### 5.1.3 DCI load error

During DC current measurement, since multimeter is not ideal and it has certain amount of input resistance, electric measurement during the situation where multimeter and test circuit are connected in series will cause error. As shown in the following figure, equate the multimeter to an ideal voltmeter, and connect with resistance R in paralleled way.

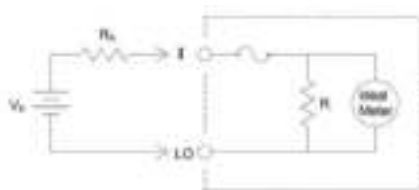

$V_s$ =Voltage source

$R_s$ =Circuit resistance

$R$ =Multimeter bypass resistance

When circuit internal resistance approximates with multimeter internal resistance, it will seriously influence measurement accuracy, then you should select multimeter's next higher measurement range to reduce the error to an acceptable level. The following table lists multimeter internal resistances under different measurement ranges

Measurement Range	Internal Resistance	Measurement Range	Internal Resistance
10uA	11k $\Omega$	100mA	1 $\Omega$
100uA	1k $\Omega$	1A	0.01 $\Omega$
1mA	100 $\Omega$	10A	0.01 $\Omega$
10mA	10 $\Omega$		

### 5.1.4 Noise control

#### Voltage controlling power-line noise

One of the advantages of integral (A/D) converter is that it can control relevant power-line noise existing in DC input signals, which is called norm noise control or NMR. Multimeter realizes norm noise control through conducting integral to DC input in a fixed time period. If the integral time is set as integer multiple of power-line period (PLC), these errors (and their harmonics) approximate to zero after being averaged.

Multimeter provides four integral options (1, 2, 10 and 100 PLC) to realize norm noise control.

Multimeter firstly measures power frequency (50Hz or 60Hz), and then determines corresponding integral time.

#### Common-mode control

In ideal situation, multimeter is totally separated from circuit benchmarked against ground.



However, there is certain amount of resistance between multimeter LO input terminal and grounding terminal, as shown in the following figure, which will cause error to measure the floated low voltage relative to the grounding terminal.

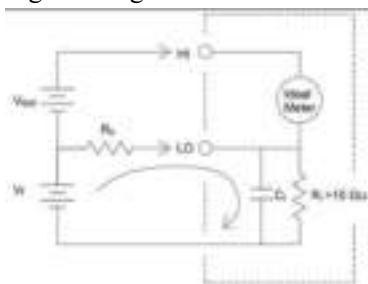

Vf=Floating ground voltage

Rs=Internal resistance of voltage source under test

Ri=Multimeter isolation resistance (LO terminal against the ground)

Ci=Multimeter input capacitance (LO terminal against the ground)

$$\text{Error}(V) = \frac{V_f \times R_i}{R_i + R_s}$$

### Noise caused by magnetic loop

If conduct measurement near magnetic field, please pay attention to take measures to avoid causing sense voltage during measurement wiring, and especially beware when working near conductor conveying high current. Use twisted-pair in connecting to reduce noise-pickup loop area, or make all the test leads close to each other as much as possible. Test lead looseness or vibration may cause induction error voltage. Fasten test leads when operating near magnetic field, and if possible, try to use magnetic shielding material or keep away from magnetic field source.

### Noise caused by grounding loop

If multimeter and equipment under test are connected to the same common ground, measurement of voltage of the circuit will cause **Ground loop**. As shown in the following, any voltage differences (Vground) between two grounding reference points will cause current going through measurement leads, thus causing noise and offset voltage (generally is associated with power-line), which are added to voltage under test.

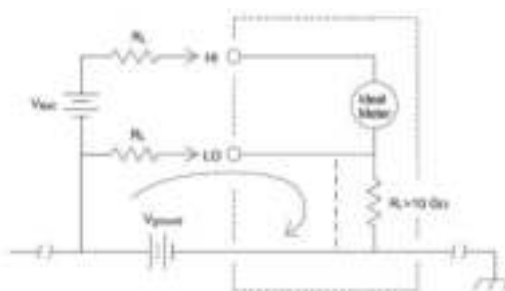

Rl=Lead resistance

Ri=Multimeter ground-isolation resistance'

Vground=Voltage drop on ground bus

The best way to eliminate ground loop is not to conduct grounding to input terminal, and use multimeter to conduct ground-isolation. If multimeter has to take ground as baseline, connect it and equipment under test to the same common ground, and if possible, connect them to the same power outlet.

## 5.1.5 Resistance measurement considerations

Multimeter provides two resistance measurement methods, that is, 2-wire and 4-wire resistance, where test current goes out from input HI terminal, and goes through resistor under test. In the 2-wire resistance measurement method, the voltage drop on resistor under test is internally sensed to multimeter, therefore, the measurement includes test lead resistance at the same time. In the 4-wire resistance measurement method, adopt independent **Sense** connection, and since the current does not go through sense lead, resistance in these leads will not cause measurement error.

The DC voltage measurement error mentioned in former part of this chapter is also suitable for resistance measurement, and error source peculiar to other resistance measurements will be discussed in latter part.

### 4-wire resistance measurement

4-wire resistance method is the most accurate method to measure low resistance, which can automatically eliminate resistance of test lead and contact resistance and is generally used for automation test under the situation where there are resistance, long-cable or plentiful connections or switches between multimeter and equipment under test. The connecting figure is as shown in the following.

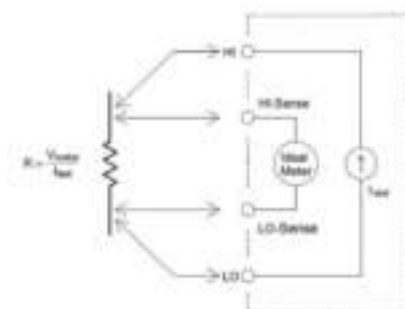

### Eliminate test lead resistance errors in 2-wire resistance measurement

Operate step by step to eliminate offset error existing in 2-wire resistance measurement and related to test lead resistance.

1. Short the two terminals of test leads together and multimeter displays test lead resistance.
2. Start **Relative measurement** function, and multimeter saves the test lead resistance as the zero-value of 2-wire resistance and subtracts the value from future measurement result.

### Minimize power consumption influence

When measure resistor is used in temperature measurement (or resistance equipment with large temperature parameters), you are required to pay attention to that multimeter will consume certain amount of power of the equipment under test. If the power consumption has much influence on measurement, you should select multimeter's next higher measurement range to reduce the error to an acceptable level.

## 5.2 AC Measurement Considerations

### 5.2.1 True virtual value AC measurement

The product adopts true virtual value to send measurement AC signals to measure potential **calorific value** in voltage. The average heating power consumed by resistor is in direct proportion to the square number of the voltage imposed to resistance, which has no relation with signal waveform. The multimeter can accurately measure true virtual value voltage or current provided that the energy contained in waveform on instrument's effective bandwidth is negligible. The effective AC voltage bandwidth of the product is 300 kHz, and effective AC current bandwidth is 5 kHz.

波形	波峰因数 (C.F.)	AC 有效值	AC+DC 有效值
	$\sqrt{2}$	$\frac{F}{\sqrt{2}}$	$\frac{F}{\sqrt{2}}$
	$\sqrt{3}$	$\frac{F}{\sqrt{3}}$	$\frac{F}{\sqrt{3}}$
	1	$\frac{F}{CF}$	$\frac{F}{CF}$

波形	波峰因数 (C.F.)	AC 有效值	AC+DC 有效值
Waveform	Crest factor	AC virtual value	AC +DC virtual value

Multimeter AC voltage and AC current functions measure the true virtual value of AC coupling, and the product only measures the **calorific value** of AC parts of input waveform (DC is controlled). As shown in the above figure, for sine wave, triangle wave and square wave, AC coupling equates to the value of AC+DC, for these waveforms do not include DC offset. However, for asymmetric waveforms (such as pulse sequence), Agilent AC coupling true virtual value measurement will control the existing DC voltage, which benefits a lot. When there is low AC signal of high DC offset during measurement, AC coupling true virtual value measurement is quite useful. For example, it is a common situation of measuring AC ripple wave existing in DC power. However, you might need to understand true virtual value of AC+DC, which you can confirm by combining DC and AC measurement results, as shown in the following:

$$RMS_{(AC+DC)} = \sqrt{AC^2 + DC^2}$$

For the best AC noise control, you should use integral time of at least 10 power-line periods (PLC) to conduct DC measurement.

### 5.2.2 Crest factor error (non-sine wave input)

Generally there exists the following misunderstanding, "Since multimeter can measure signal true virtual value, its sine wave accuracy indicator is absolutely suitable for input signals in other waveforms". Actually, the waveform of input signals will influence measurement accuracy. Generally, signal waveform is described by crest factor which is the ratio between waveform crest and its virtual value, and the larger the crest factor is, the more energy the high-frequency harmonic contains. All the multimeters have errors related to crest factor, and crest factor error of the product is listed in the indicators of **AC Characteristic** in Chapter 6.

Measurement error caused by signal crest factor can be evaluated as follows:

Error sum=error (sine wave) +error (crest factor) +error (bandwidth)

Error (sine wave): Sine wave error (as indicated in Chapter 6)

Error (crest factor): Crest factor plus error (as indicated in Chapter 6).

Error (bandwidth): Bandwidth error can be evaluated according to the following formula.

$$\text{Bandwidth error} = \frac{C.F.^2 \times F}{4 \times BW} \times 100\% \quad (\% \text{ of the reading})$$

**C.F.** refers to signal crest factor

**F** refers to fundamental frequency for pulse

**BW** refers to -3db bandwidth of multimeter, and VICTOR 8165A and 8165 are 1MHz

Example:

In calculation of approximate measurement error input in pulse sequence, the crest factor is 3, and fundamental frequency is 20 kHz.

Assume that multimeter's ninety-day accuracy is  $\pm (0.05\% \text{ of the reading}) + (0.03\% \text{ of the measurement range})$ .

Error sum =  $(0.05\% \text{ of the reading} + 0.03\% \text{ of the measurement range}) + (15\% \text{ of the reading}) + (1.4\% \text{ of the reading}) = 1.6\% \text{ of the reading} + 0.03\% \text{ of the measurement range}$

### 5.2.3 ACV load error

When using AC voltage measurement function, multimeter input impedance is  $1M\Omega$ , with resistance being connected to 100pF capacitance in paralleled way, and multimeter test leads also will introduce some capacitance and load. During low-frequency input, it equates to  $1M\Omega$  resistance, and during high-frequency input, it equates to 100pF capacitance. The following table displays approximate values of multimeter input impedances under different frequencies

Input Frequency	Input Impedance
100Hz	$1M\Omega$
1kHz	$850k\Omega$
10kHz	$160k\Omega$
100kHz	$16k\Omega$

## 6. Indicators

Input protection: 1000V, all-in-one;

Over measurement range measuring ability: 20%

Function switching rate:  $\geq 25\text{sps}^{(\text{note})}$ ;

Measurement range exchanging rate:  $\geq 50\text{sps}^{(\text{note})}$ ;

Automatic-shift time:  $\leq 30\text{ms}^{(\text{note})}$ ;

Maximum internal trigger rate:  $\geq 2000\text{sps}^{(\text{note})}$ ;

Maximum external trigger rate to the memory:  $\geq 2000\text{sps}^{(\text{note})}$ ;

**Note: Test condition is under the condition of 4 1/2 digits, AZ off, display off; these rates are not lower than measurement rate under other conditions.**

Function	Digit	Setting	Integral time	Measurement/second [1]
DC voltage	6 1/2	100PLC	2s	0.5
DC current	6 1/2	10PLC	200ms	5
Resistance	6 1/2	2PLC	40ms	25
	5 1/2	1PLC	20ms	50
	5 1/2	0.2PLC	4ms	250
	4 1/2	0.1	2ms	500
	4 1/2	0.02	0.4ms	2500
	AC voltage	6 1/2	3Hz	
AC current	6 1/2	20Hz		1
	6 1/2	200Hz		1.6
	6 1/2	200Hz		6
	6 1/2	200Hz		6
Frequency and period	6 1/2	1s		1
	5 1/2	100ms		9.8
	4 1/2	10ms		80

[1] The typical measurement rate during AZ off, AZ integral time should not be more than signal integral time.

Uncertainty indicator refers to the technical indicator 1 hour after pre-heating and in using **Auto Zero** function, and the 24-hour indicator is relative to calibration standard, and test standard complies with *GB/T 13978-2008 Digit Multimeter*.

## 6.1 DC Characteristics

### 6.1.1 Basic characteristics

DC voltage:

Maximum input:  $\geq 1000V$ , all the measurement ranges;

Common mode control:  $\geq 140dB$ , 50 or 60Hz  $\pm 0.1\%$  (1k $\Omega$  imbalance);

Series-mode control:  $\geq 60dB$ , when PLC is 1 or more and power frequency is  $\pm 0.1\%$ ;

$\geq 0dB$ , when PLC is  $< 1$ ;

Input resistance: 100mv, 1V and 10V measurement ranges: 10M $\Omega$  or  $> 10G\Omega$  are available

100V and 1000V measurement ranges: 10M $\Omega \pm 1\%$

Measurement method: Multi-slope mode converter;

A/D linearity: 2ppm measurement value+1ppm measurement range;

Input offset current: when it is  $< 30pA$  and 25 $^{\circ}C$ .

DC current:

Input protection: built-in fuses+ external replaceable fuses

Resistance:

The listed indicator is four-wire or two-wire resistance measurement function adopting zero setting function. If it does not adopt zero setting function, it is allowed to increase

error during two-wire resistance measurement ( $0.2\Omega$ +test lead resistance)

Measurement method: Standard constant flow source conversion, with current source relative to LO input.

Maximum wire resistance (four-wire): for  $100\Omega$  and  $1k\Omega$  measurement ranges are 10% of measurement ranges; other measurement ranges are all  $1k\Omega$ /wire.

Current source accuracy: 3%.

On-off test:

On-off threshold:  $1\Omega$ - $1000\Omega$ , which can be set by users.

Test current:  $1mA\pm 3\%$ .

Response time: 300 samples/second.

Display resolution:  $0.1\Omega$ .

Diode test:

Test current:  $1mA\pm 3\%$ .

Beeping indication threshold:  $0.3V \cong \text{test voltage} \cong 3V$ .

Response time: 300 samples/second.

Display resolution: 10ppm.

Ratio measurement:

Measurement method: Input terminal HO-LO/Reference terminal HO-LO

Input voltage:  $100mV$ - $100V$ , automatic shift;

Reference voltage:  $100mV$ - $10V$ , automatic shift.

## 6.2 Uncertainty Indicators

Accuracy is expressed by  $\pm$  (ppm measurement value + ppm measurement range) [1]

Function	Measurement range [2]	Resolution [5]	Test current, load voltage, etc.	24-hour [3] (23±1°C)	90 days(23±5 °C)	1 year (23±5°C)	Temperature coefficient 0°-18°/28-55°
DC voltage	100 mV	100 nV	10MΩ or>10 GΩ	30+30	40+35	50+35	5+5
	1 V	1 uV	10MΩ or>10 GΩ	20+6	30+7	40+7	5+1
	10 V	10 uV	10MΩ or>10 GΩ	15+4	20+5	35+5	5+1
	100 V	100 uV	10 MΩ ± 1%	20+6	35+6	40+6	5+1
	1000 V	1 mV	10 MΩ ± 1%	20+6	35+6	40+6	5+1
DC current	10uA	10pA	< 140mV	100+200	400+250	500+250	20+30
	100uA	100pA	< 140mV	100+200	400+250	500+250	20+30
	1mA	1nA	< 160mV	70+60	300+60	500+60	20+5
	10mA	10nA	< 160mV	70+200	300+200	500+200	20+20
	100mA	100nA	< 400mV	100+40	300+50	500+50	20+5
	1A	1uA	< 60mV	500+60	800+100	500+200	50+10
	10A	10uA	< 600mV	1000+200	1200+200	1500+200	50+20
Resistance[4]	10Ω	10uΩ	10mA	30+30	80+40	100+40	6+5
	100Ω	100uΩ	1mA	30+30	80+40	100+40	6+5
	1kΩ	1mΩ	1mA	20+5	70+10	100+10	6+1
	10kΩ	10mΩ	100uA	20+5	70+10	100+10	6+1
	100kΩ	100mΩ	50uA	20+5	70+10	100+10	6+1
	1MΩ	1Ω	5uA	20+10	100+10	120+10	10+2
	10MΩ	10Ω	0.5uA	100+10	300+10	400+20	30+4
	100MΩ	100Ω	0.5uA  10MΩ	2000+100	6000+100	8000+100	1000+10
Diode	1V	10uV	1mA	20+100	80+200	100+200	10+20
	10V	100uV	1mA	20+100	80+200	100+200	10+20
On-off test	1kΩ	0.1Ω	1mA	20+100	80 + 200	100 + 200	10 + 20
Ratio measurement DCV:DCV	100mV-1000V	Input terminal indicator + reference terminal indicator					

[1] Pre-heat for 60 minutes, and integral time is set as 100PLC.

[2] Except for DCV 1000V shift and DCI 10A shift, other measurement ranges can have 20% of over measurement range measurement.

[3] Relative to calibration standard.

[4] This indicator is suitable for 4-wire resistance measurement or 2-wire resistance measurement under relative mode.

[5] This indicator is suitable when the digit is displayed as 6 1/2.

## 6.2.1 Additional error

Integral time Power period number NPLC	Digit	Additional error		
		DC voltage (% of measurement range)	DC current (% of measurement range)	Resistance (% of measurement range)
100 PLC	6½	0	0	0
10 PLC	6½	0	0	0
2 PLC	6½	0	0	0
1 PLC	5½	0.001	0.001	0.001
0.2 PLC	5½	0.001 + 20uV	0.001 + 4uA	0.001 + 20m Ω
0.1PLC	4½	0.002 + 20uV	0.002 + 4uA	0.002 + 20 m Ω
0.02PLC	4½	0.010 + 20uV	0.010 + 4uA	0.010 + 20 m Ω

## 6.3 AC Characteristics

### 6.3.1 Basic characteristics

AC voltage:

AC voltage technical indicator refers to the technical indicator under AC sine signal with >5% measurement range, and for the 1%-5% measurement ranges and <50 kHz signals, the allowable increased error is 0.1% of the measurement range, and for frequency of 50kHz-100kHz, the allowable increased error is 0.13% of the measurement range.

Maximum input: 750Vrms.

Input impedance:  $1\text{ M}\Omega \pm 1\%$ , shunt capacitance <100pF

Measurement method: AC coupling, virtual value response.

Maximum DC offset: not lower than 1000V.

AC filter bandwidth:

Slow: 3Hz-300 kHz;

Mid: 20Hz-300kHz;

Fast: 200Hz-300kHz;

Common mode control: 70 dB, 50Hz (or 60 Hz)  $\pm 0.1\%$  (1 k Ω imbalance).

Maximum crest factor (CF): 5:1, in case of full measurement range.

Additional crest factor error (<100 Hz): CF 1-2, 0.05 %;

CF 2-3, 0.2 %;

CF 3-4, 0.4 %;

CF 4-5, 0.5 %.

Voltage frequency product:  $8 \times 10^7\text{HzV}$ , all the measurement ranges.

Sine wave transfer accuracy: 10Hz-50kHz: 20ppmFS;

50kHz-300kHz: 50ppmFS.

AC current:

The following AC current technical indicator refers to the technical indicator of sine wave whose amplitude is larger than 5% of measurement range, and for input of 1%-5% of measurement range, the allowable increased additional error is 0.1% of the measurement range.

Input protection: Built-in fuses + external replaceable fuses;

Measurement method: AC coupling, virtual value response;



DC coupling to fuses and shunt (no blocking capacitor);

AC filter bandwidth:

Slow: 3Hz-10 kHz;

Mid: 20Hz-10kHz;

Fast: 200Hz-10kHz;

Maximum crest factor (CF): 5:1, in case of full scale;

Additional CF error (<100 Hz): CF 1-2, 0.05% of the full scale;

CF 2~3, 0.2% of the full scale;

CF 3~4, 0.4% of the full scale;

CF 4~5, 0.5% of the full scale.

## 6.3.2 Uncertainty indicators

Accuracy is expressed by  $\pm$  (% measurement value + % measurement range) [1]

Function	Measurement range [2]	Resolution	Frequency	24-hour [5] (23±1°C)	90 days(23±5°C)	1 year (23±5°C)	Temperature coefficient 0°-18°/28-55
DC voltage	100 mV	100 nV	3Hz~5Hz	1.00+0.03	1.00+0.04	1.00+0.04	0.100 + 0.004
			5Hz~10Hz	0.35+0.03	0.35+0.04	0.35+0.03	0.035+ 0.004
			10Hz~20kHz	0.04+0.03	0.05+0.04	0.06+0.04	0.005+ 0.004
			20kHz~50kHz	0.10+0.05	0.11+0.05	0.12+0.05	0.011+ 0.005
			50kHz~100kHz	0.55+0.08	0.60+0.08	0.60+0.08	0.060+ 0.008
			100k~300kHz[3]	4.00+0.50	4.00+0.50	4.00+0.50	0.20 + 0.02
	1 V 10V 100V 750 V	1uV 10uV 100uV 1mV	3Hz~5Hz	1.00+0.02	1.00+0.03	1.00+0.03	0.100 + 0.003
			5Hz~10Hz	0.35+0.02	0.35+0.03	0.35+0.03	0.035+ 0.003
			10Hz~20kHz	0.04+0.02	0.05+0.03	0.06+0.03	0.005+ 0.003
			20kHz~50kHz	0.10+0.04	0.11+0.05	0.12+0.05	0.011+ 0.005
			50k~100kHz[4]	0.55+0.08	0.60+0.08	0.60+0.08	0.060+ 0.008
			100k~300kHz[3]	4.00+0.50	4.00+0.50	4.00+0.50	0.20 + 0.02
AC current	100 μA	100 pA	3Hz~5 Hz	1.0 + 0.04	1.0 + 0.04	1.0 + 0.04	0.100 + 0.006
			5Hz~10 Hz	0.3 + 0.04	0.3 + 0.04	0.3 + 0.04	0.035 + 0.006
			10Hz~5 kHz	0.1 + 0.04	0.1 + 0.04	0.1+ 0.04	0.015 + 0.006
			5kHz~10 kHz	0.3 + 0.04	0.3 + 0.04	0.3+ 0.04	0.015 + 0.006
	1 mA	1 nA	3Hz~5 Hz	0.1 + 0.04	0.1 + 0.04	0.1+ 0.04	0.100 + 0.006
			5Hz~10 Hz	0.3 + 0.04	0.3 + 0.04	0.3 + 0.04	0.035 + 0.006
			10Hz~5 kHz	0.1 + 0.04	0.1 + 0.04	0.1+ 0.04	0.015 + 0.006
			5kHz~10 kHz	0.3 + 0.04	0.3 + 0.04	0.3+ 0.04	0.015 + 0.006
	10 mA	10 nA	3Hz~5 Hz	1.1 + 0.06	1.1 + 0.06	1.1 + 0.06	0.200 + 0.006
			5Hz~10 Hz	0.35 + 0.06	0.35 + 0.06	0.35 + 0.06	0.100 + 0.006
			10Hz~5 kHz	0.15 + 0.06	0.15 + 0.06	0.15 + 0.06	0.015 + 0.006
			5kHz~10 kHz	0.3 + 0.04	0.3 + 0.04	0.3+ 0.04	0.015 + 0.006
	100 mA	100 nA	3Hz~5 Hz	1.0 + 0.04	1.0 + 0.04	1.0 + 0.04	0.100 + 0.006
			5Hz~10 Hz	0.3 + 0.04	0.3 + 0.04	0.3 + 0.04	0.035 + 0.006
			10Hz~5 kHz	0.1 + 0.04	0.1 + 0.04	0.1 + 0.04	0.015 + 0.006
			5kHz~10 kHz	0.3 + 0.04	0.3 + 0.04	0.3+ 0.04	0.015 + 0.006
	1 A	1 μA	3Hz~5 Hz	1.0 + 0.04	1.0 + 0.04	1.0 + 0.04	0.100 + 0.006
			5Hz~10 Hz	0.3 + 0.04	0.3 + 0.04	0.3 + 0.04	0.035 + 0.006
			10Hz~5 kHz	0.1 + 0.04	0.1 + 0.04	0.1 + 0.04	0.015 + 0.006
			5kHz~10 kHz	0.3 + 0.04	0.3 + 0.04	0.3+ 0.04	0.015 + 0.006
	10A	10 μA	3Hz~5 Hz	1.1 + 0.06	1.1 + 0.06	1.1 + 0.06	0.100 + 0.006
			5Hz~10 Hz	0.35 + 0.06	0.35 + 0.06	0.35 + 0.06	0.350 + 0.006
			10Hz~5 kHz	0.15 + 0.06	0.15 + 0.06	0.15 + 0.06	0.015 + 0.006
			5kHz~10 kHz	0.3 + 0.04	0.3 + 0.04	0.3+ 0.04	0.015 + 0.006

- [1] Pre-heat for 60 minutes, slow AC filter and sine signal input.  
 [2] Except for ACV 750V, ACI 12A measurement ranges, other measurement ranges can have 20% of over measurement range measurement.  
 [3] Typical error under 1MHz is 30% of the reading.  
 [4] AC 750V measurement range is restricted to 100KHz or  $8 \times 10^7$  voltage frequency product.  
 [5] Relative to standard calibration.

### 6.3.3 Additional error

Additional low-frequency error (% of the reading)				Additional crest factor error (non-sine wave)	
Frequency	AC filter			Crest coefficient	Error (% of the reading)
	Slow	Mid	Fast		
				1-2	0.05
10Hz-20Hz	0	0.74	\	2—3	0.15
20Hz-40Hz	0	0.22	\	3—4	0.30
40Hz-100Hz	0	0.06	0.73	4—5	0.40
100Hz-200Hz	0	0.01	0.22		
200Hz-1kHz	0	0	0.18		
>1kHz	0	0	0		

## 6.4 Frequency and Period Characteristics

Gate time can be set as 1s, 100ms and 10ms or a wider range.

Stability refers that after DC offset voltage changes, the time to reach stable and accurate measurement result is not longer than 1 second.

Measurement method is that equal precision frequency testing technology and AC coupling input use AC voltage measurement function.

### 6.4.1 Uncertainty indicators

Accuracy is expressed by  $\pm$  (ppm measurement value) [1]

Function	Measurement range [2]	Frequency	24-hour [3] (23 $\pm$ 1 $^{\circ}$ C)	90 days(23 $\pm$ 5 $^{\circ}$ C)	1 year (23 $\pm$ 5 $^{\circ}$ C)	Temperature coefficient 0 $^{\circ}$ -18 $^{\circ}$ /28-55 $^{\circ}$
Frequency period	100 mV-750V[4]	3-5 Hz	500	500	500	20
		5-10 Hz	300	300	300	20
		10-40 Hz	200	200	200	10
		40Hz-300kHz	50	100	100	10

- [1] Pre-heat for 60 minutes, and use 1 second of gate time.  
 [2] Except for 750V measurement ranges, other measurement ranges can have 20% of over measurement range measurement.  
 [3] Relative to standard calibration.  
 [4] Input >100mV. For 10mV-100mV, multiply percentage measurement error by 10.

## 6.4.2 Low-frequency additional error

Frequency	Gate time (resolution)		
	1 second (6 1/2)	0.1 second (6 1/2)	0.01 second (6 1/2)
3Hz-5Hz	0	0.12	0.12
5Hz-10Hz	0	0.17	0.17
10Hz-40Hz	0	0.20	0.20
40Hz-100Hz	0	0.06	0.21
100Hz-300Hz	0	0.03	0.21
300Hz-1kHz	0	0.01	0.07
>1kHz	0	0	0.02

## 6.5 Capacitance

Accuracy is expressed by  $\pm$  (% of measurement value+% of measurement range) [1]

Function	Measurement range	Test current	Resolution	Display speed	Annual accuracy % of the reading + % of measurement range	Temperature coefficient % of the reading + % of measurement range
Capacitance measurement	1nF	10uA	1pF	$\geq 2$ sps	2+2.5	0.05+0.05
	10nF	10uA	10pF	$\geq 2$ sps	1+0.3	0.05+0.01
	100nF	100uA	100pF	$\geq 2$ sps	1+0.3	0.01+0.01
	1uF	1mA	1nF	$\geq 2$ sps	1+0.3	0.01+0.01
	10uF	1mA	10nF	$\geq 2$ sps	1+0.3	0.01+0.01
	100uF	1mA	0.1uF	$\geq 2$ sps	1+0.3	0.01+0.01
	1000uF	10mA	1uF	$\geq 2$ sps	1+0.3	0.01+0.01
	10mF	10mA	0.01mF	$\geq 2$ sps	1+0.3	0.01+0.01
	100mF	10mA	0.1mF	$\geq 2$ sps	3+0.2	0.05+0.02

[1] Pre-heat for 60 minutes, and use **Relative** operation function.

## 6.6 Temperature

Accuracy is expressed by  $\pm$  °C [1]

Function	Type	Test current	Best range	Display speed	Annual accuracy	Temperature coefficient
Temperature test	Pt100	1mA	-200 to 660°C	$\geq 2$ sps	0.16°C	0.01°C
	Pt1000	100uA	-200 to 660°C	$\geq 2$ sps	0.16°C	0.01°C

[1] Pre-heat for 60 minutes, technical indicator does not include probe accuracy, and it has to add probe accuracy during calculation.

[2] Indicator means that sensor uses four-wire resistance measurement or two-wire resistance measurement using **Relative** operation.