

# USER'S GUIDE

## Humidity and Temperature USB Datalogger

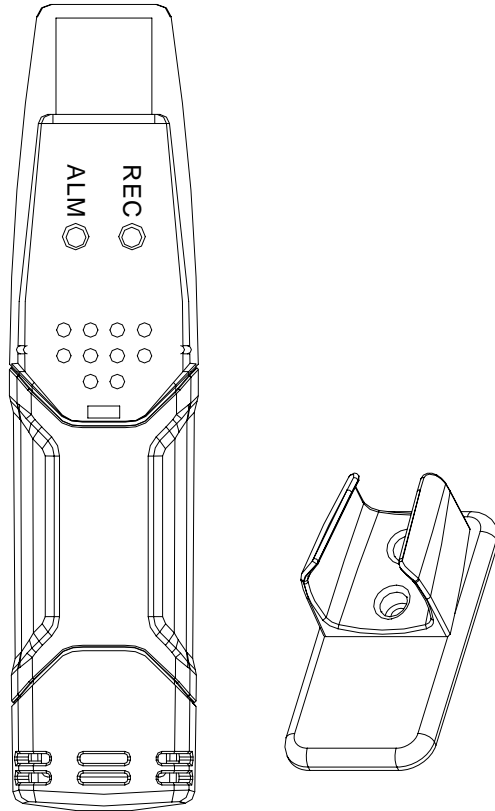

## FEATURES

- Memory for 32,000 readings  
(16000 temperature and 16,000 humidity readings)
- Dew point indication
- Status Indication
- USB Interface
- User-Selectable Alarm
- Analysis software
- Multi-mode to start logging
- Long battery life
- Selectable measuring cycle:  
2s, 5s, 10s, 30s, 1m, 5m, 10m, 30m, 1hr, 2hr, 3hr, 6hr, 12hr, 24hr

## DISCRIPTION

1. Protective cover
2. USB connector to PC port
3. Start button
4. RH and Temperature sensors
5. Alarm LED(red/yellow)
6. Record LED(green)
7. Mounting clip

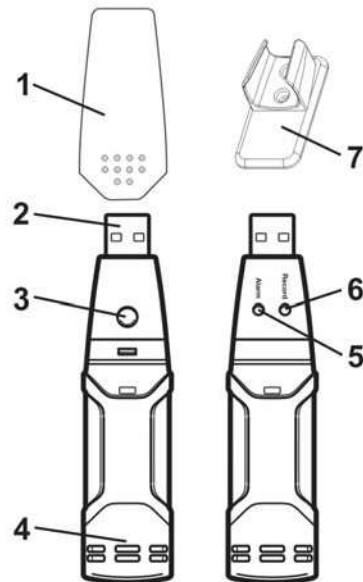

## LED STATUS GUIDE

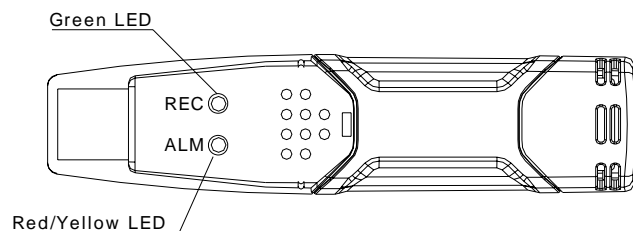

## LED STATUS GUIDE

LEDs	Indication	Action
<p>REC    ALM</p> <p>○      ○</p>	<p><b>Both LED lights OFF</b></p> <p><b>Logging not active</b> <b>Or</b> <b>Low Battery</b></p>	<p><b>Start logging</b></p> <p><b>Replace battery and download the data</b></p>
<p>REC    ALM</p> <p>●      ○</p>	<p><b>One green flash every 10 sec. *</b> <b>Logging, no alarm condition**</b></p> <p><b>Green double flash every 10 sec. *</b> <b>Delayed start</b></p>	<p><b>To start, hold the start button until Green and Yellow LED flash</b></p>
<p>REC    ALM</p> <p>○      ●</p>	<p><b>Red single flash every 10 sec. *</b> <b>-Logging, low alarm for RH***</b></p> <p><b>Red double flash every 10 sec. *</b> <b>-Logging, high alarm for RH***</b></p> <p><b>Red single flash every 60 sec.</b> <b>- Low Battery****</b></p>	<p><b>If logging, it will stop automatically. No data will be lost. Replace battery and download data</b></p>
<p>REC    ALM</p> <p>○      ●</p>	<p><b>Yellow single flash every 10 sec. *</b> <b>-Logging, low alarm for TEMP***</b></p> <p><b>Yellow double flash every 10 sec. *</b> <b>-Logging, high alarm for TEMP***</b></p> <p><b>Yellow single flash every 60 sec.</b> <b>- Logger memory full</b></p>	<p><b>Download data</b></p>

\* To save power, the logger's LED flashing-cycle can be changed to 20s or 30s via the supplied software.

\*\* To save power, alarm LEDs for temperature and humidity can be disabled via the supplied software.

\*\*\*When both temperature and relative humidity readings exceed alarm level synchronously, LED status indication alternate every cycle. For example: If there is only one alarm, the REC LED blinks for one cycle and alarm LED will blink for next cycle. If there are two alarms, REC LED will not blink. First alarm will blink for first cycle and the next alarm will blink for next cycle.

\*\*\*\*When the battery is low, all operations will be disabled automatically. NOTE: Logging automatically stops when the battery weakens (logged data will be retained). The supplied software is required to restart logging and to download logged data.

\*\*\*\*\* To use the delay function. Run the datalogger Graph software, click on the computer icon on the menu bar (2nd from left) or select LOGGER SET from the LINK pull-down menu. The Setup window will appear, and you will see there are two options: Manual and Instant. If you select the Manual option, after you click the Setup button, the logger won't start logging immediately until you press the yellow button in logger's housing.

## SPECIFICATIONS

Relative Humidity	Overall Range	0 to 100%
	Accuracy (0 to 20 and 80 to 100%)	±5.0%
	Accuracy (20 to 40 and 60 to 80%)	±3.5%
	Accuracy(40 to 60%)	±3.0%
Temperature	Overall Range	-40 to 70°C (-40 to 158°F)
	Accuracy(-40 to -10 and +40 to +70°C)	±2°C
	Accuracy(-10 to +40°C)	±1°C
	Accuracy (-40 to +14 and 104 to 158°F)	±3.6°F
	Accuracy(+14 to +104°F)	±1.8°F
Dew point Temperature	Overall Range	-40 to 70°C (-40 to 158°F)
	Accuracy(25°C, 40 to 100%RH)	±2.0°C(±4.0°F)
Logging rate	Selectable sampling interval: From 2 seconds up to 24 hours	
Operating temperature	-35 to 80°C (-31 to 176°F)	
Battery type	3.6V lithium(1/2AA)(SAFT LS14250, Tadiran TL-5101 or equivalent)	
Battery life	1 year(typ.) depending on logging rate, ambient temperature & use of Alarm LEDs	
Dimensions/Weight	101x25x23mm (4x1x.9")/ 172g (6oz)	

## BATTERY REPLACEMENT

Only use 3.6V lithium batteries. Before replacing the battery, remove the model from the PC. Follow diagrammatic and explanation steps 1 through 4 below:

1. With a pointed object(d.g. a samll screwdriver or similar), open the casing. Lever the casing off in the direction of the arrow.
2. Pull the data logger from the casing.
3. Replace/Insert the battery into the battery compartment observing the right polarity. The two displays briefly light up for control purposes(alternating, green, yellow, green).
4. Slide the data logger back into the casing until it snaps into place. Now the data logger is ready for programing.

### NOTE:

Leaving the model plugged into the USB port for longer than necessary will cause some of the battery capacity to be lost.

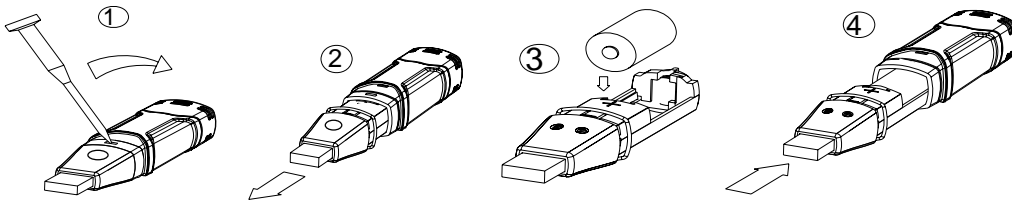

 **WARNING:** Handle lithium batteries carefully, observe warnings on battery casing. Dispose of in accordance with local regulations.

## Sensor Reconditioning

Over time, the internal sensor may be compromised as a result of pollutants, chemical vapors, and other environmental conditions which can lead to inaccurate readings. To recondition the internal sensor, please follow the procedure below:

Bake the Logger at 80°C (176°F) at <5%RH for 36 hours followed by 20-30°C (70-90°F) at >74%RH for 48 hour ( for re-hydration)

If permanent damage to the internal sensor is suspected, replace the Logger immediately to insure accurate readings.