

FT0345 Weather Station with PC Software

User Manual

1. Introduction.....	1
2. Warnings and Cautions.....	1
3. Getting Started.....	1
3.1 Parts List.....	1
3.2 Recommend Tools.....	5
3.3 Sensor Assembly Set Up.....	5
3.3.1 Wind Vane Installation.....	6
3.3.2 Wind Cup Installation.....	8
3.3.3 Rain Gauge Installation.....	9
3.3.4 Battery Installation.....	10
3.3.5 Reset Integrated Outdoor Sensor.....	11
3.4 Display Console.....	12
3.4.1 Layout of Display Console.....	12
3.4.2 Setup the Display Console	13
3.4.3 Connect Sensors with Display Console.....	15
3.5 Sensor Operation Verification.....	15
4. Sensors Pre-Installation.....	16
4.1 Test the Sensors Before Installation.....	16
4.2 Site Survey Before Installation.....	16
4.3 Best Practices for Wireless Communication.....	17
5. Final Installation of Sensors.....	19
5.1 Integrated outdoor Sensor Installation.....	19
6. Low Battery Icon.....	24
7. Display Console Operation.....	24
7.1 Quick Display Mode.....	24
7.2 Set (Program) Mode.....	26

7.3 Sensor Search Mode.....	28
7.4 History Graph Mode.....	29
7.5 Max/Min Viewing and Reset Mode.....	29
7.6 Snooze Mode.....	30
7.7 Backlight Mode.....	30
8. Alarm Mode.....	31
8.1 Alarm Triggered.....	32
8.2 View High/Low Alarms Value.....	32
8.3 Setting the Alarms.....	32
8.4 Alarm and Key Beeper ON/OFF.....	34
9. Optional Calibration Mode.....	35
9.1 Calibration of Temperature Mode.....	36
9.2 Calibration of Humidity Mode.....	36
9.3 Calibration of Sensors Mode.....	37
10. Other Features of Display Console.....	42
10.1 Weather Forecasting.....	42
10.2 Weather Icons.....	43
10.3 Moon Phase.....	44
10.4 Storm Threshold Indication.....	45
10.5 Pressure Threshold Setting.....	45
10.6 Feels Like Temperature	45
10.7 Restore Factory Default.....	47
11. PC Software.....	47
12. Trouble Shooting Guide.....	54
13. Specification.....	56

1.Introduction

Thank you for your purchase of the Professional Wireless Weather Station. The following user guide provides step by step instructions for installation, operation and troubleshooting.

2.Warnings and Cautions

 **Warning:** Any metal object may attract a lightning strike, including your weather station mounting pole. Never install the weather station in a storm.

 **Warning:** Installing your weather station in a high location may result in injury or death. Perform as much of the initial check out and operation on the ground and inside a building or home. Only install the weather station on a clear, dry day.

3.Getting Started

The weather station consists of a display console, a sensor array with Integrated Outdoor Sensor, and mounting hardware.

3.1 Parts List

The weather station consists of the following parts (as referenced in Figure 1).

QTY	Item	Image
1	<p>Display Console Frame Dimensions: 5.6x4.7x0.87inch (14.2x12x2.2cm) LCD Dimensions: 4.4x3.7inch (11.2x9.4cm)</p>	
1	<p>Integrated Outdoor Transmitter Dimensions: 15x7.1x11inch (380x180x280mm)</p>	
1	<p>Wind Vane Dimensions:6.7x1.6x2inch (170x40 x 50mm)</p>	
1	<p>Wind speed Dimensions: 5.1x 5.1x1.6inch (130x130x40mm)</p>	
1	<p>Rain Funnel Dimensions:4.7x2.8inch (Φ120x70mm)</p>	

QTY	Item	Image
4	Washer(Metal gasket)	
4	Pole Mounting U-bolt Nuts (M5)	
2	U-Bolt (M5) Dimensions: 2.4x2.4x0.2inch (60x60x5mm)	
1	L-shaped Stainless Steel base Dimensions: 3x1.6x0.6inch (75x40x15mm)	
1	Wrench (M5) Dimensions: 2.6x0.8x0.08inch (65x20x2mm)	

QTY	Item	Image
1	Screwdriver (M3) Dimensions: 0.4x3.5inch (Φ10x90mm)	
2	Wind Vane and wind Cup mounting screws (Ø3) Dimensions: M2*6mm(0.23inch)	
2	Wind Vane and wind Cup Waterproof rubber plug Dimensions: 0.16x0.12inch (Φ4 x 3mm)	
1	Manual	
1	Power Adapter	
1	USB Cable 1M(3.3ft)+ Disk(CD 2.5in)	

Figure 1

3.2 Recommend Tools

- Precision screwdriver (for small Phillips screws)
- Compass or GPS (for wind direction calibration)
- Adjustable Wrench

3.3 Sensor Assembly Set Up

 **Note:** The outdoor sensor array must be powered and updating before powering up the console, or the console will stop scanning and connecting with the sensors.

The following illustration shows the full segment of integrated outdoor sensors, as shown in Figure 2.

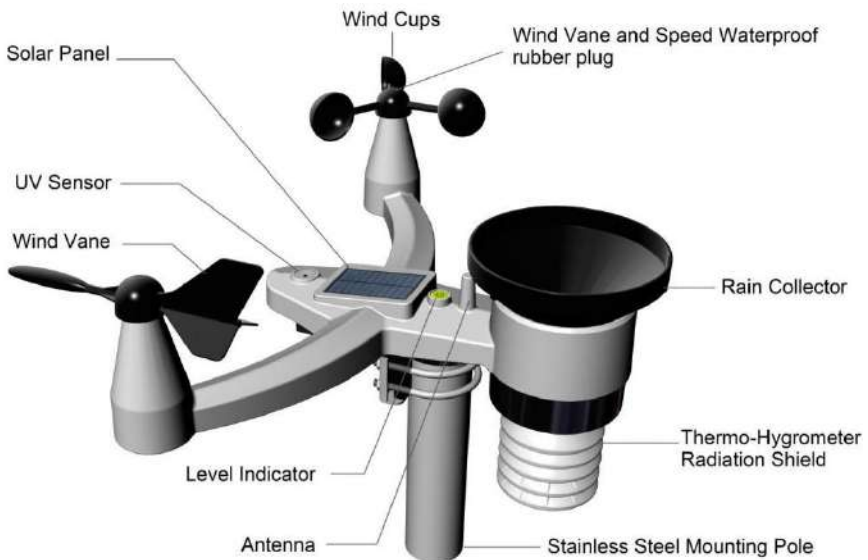

Figure 2

3.3.1 Wind Vane Installation

1) Find the “ S ” Letters on the wind vane shaft.



2) Align the wind vane with the shaft axis and push into the top of the wind vane sensor.



3) Tighten the set screw with screwdriver, until the wind van cannot be removed from the axle.

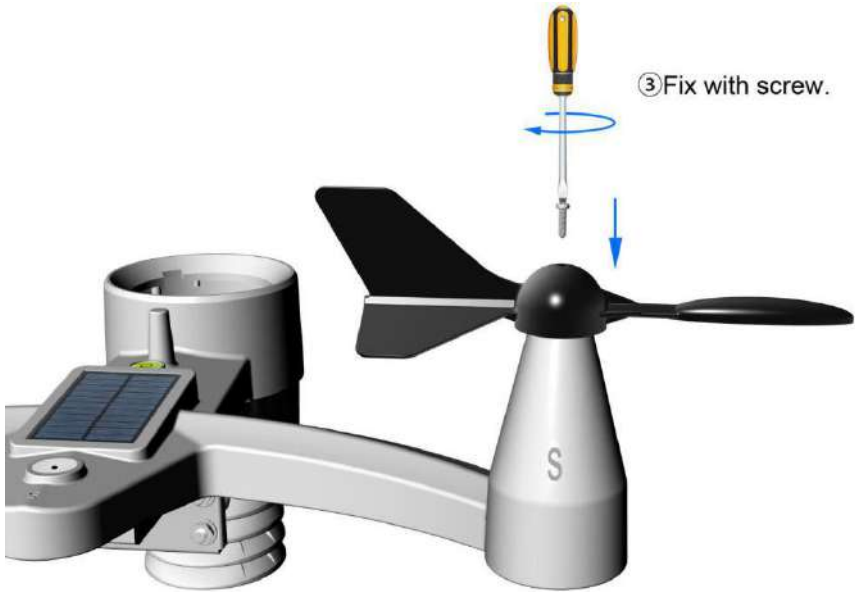

4) Insert the waterproof rubber plug into the wind vane hole and rotate to make sure it spin freely.

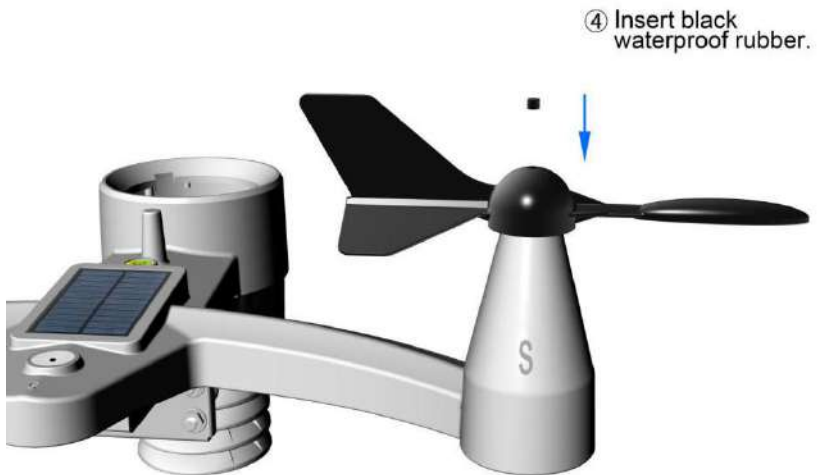

3.3.2 Wind Cup Installation

1) Align the wind cup with the shaft axle and push into the top of the wind speed sensor.

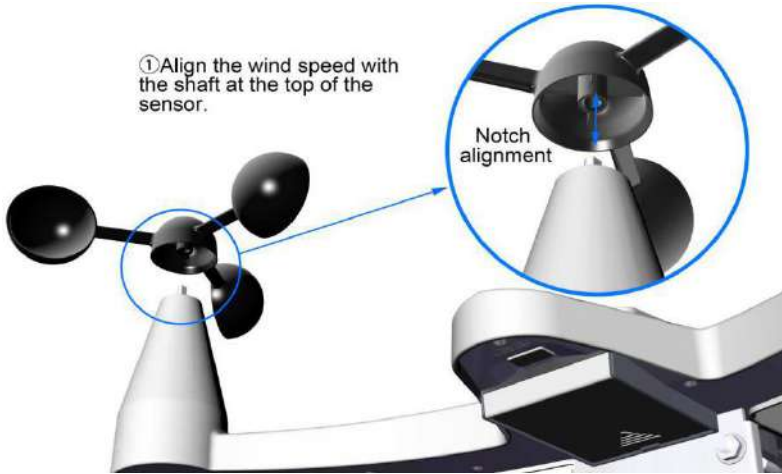

2) Tighten the set screw with screwdriver, until the wind van cannot be removed from the axle.



3) Insert the waterproof rubber plug into the wind vane hole and rotate to make sure it spin freely.

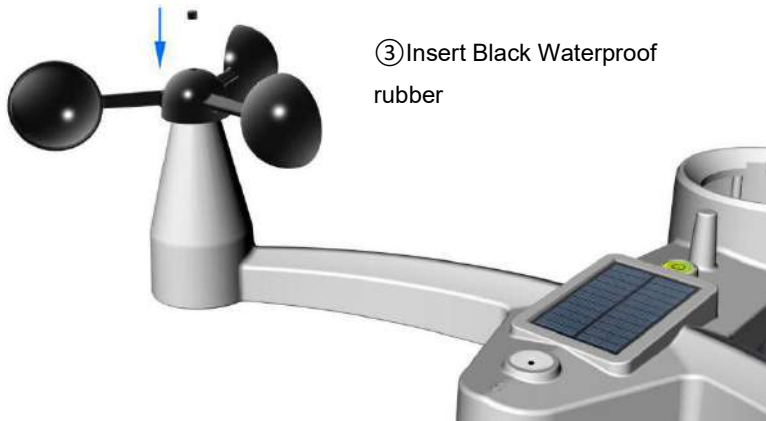

3.3.3 Rain Gauge Installation

1) Align the rain collector with the bucket notch and push into the top of the bucket.

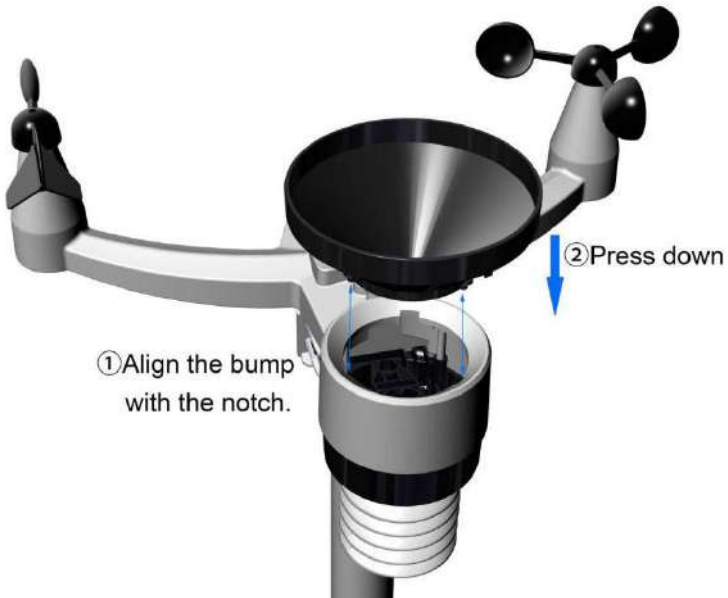

2) Rotate the rain collector clockwise and make sure it installed tightly.

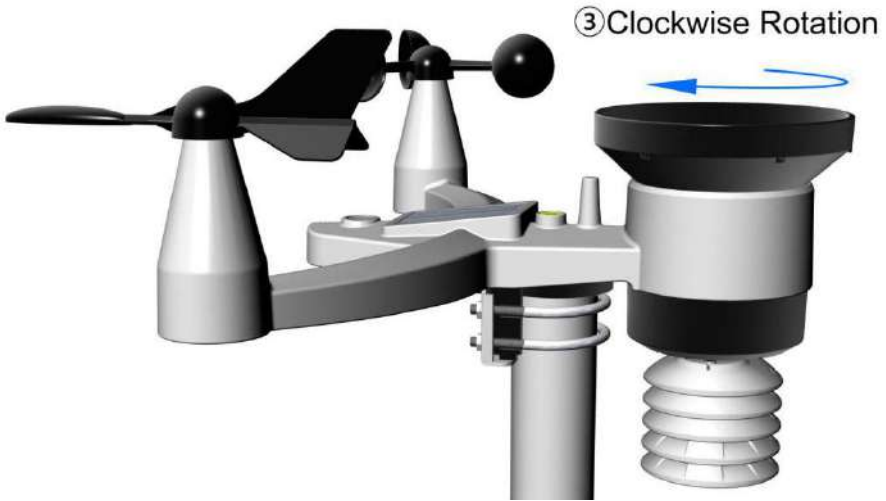

3.3.4 Battery Installation

1) Locate the battery door on the back and push outwards to open the battery door.

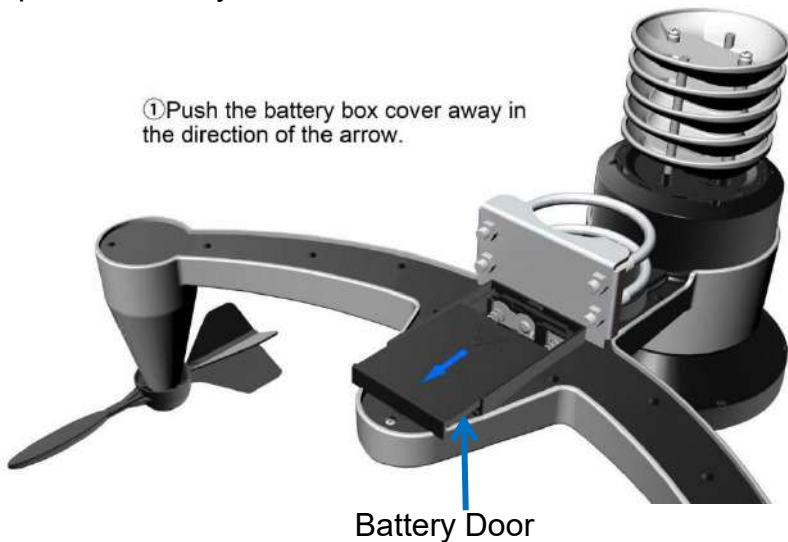

2) Inserting 3xAA batteries into the battery compartment, and close the battery door.



 **Note: Do not install the batteries backwards.** You can permanently damage the outdoor sensors. The solar panel does not charge the batteries, so rechargeable batteries are not recommended.

 **Note:** We recommend installing Lithium AA batteries for outdoor sensors in cold weather environments

3.3.5 Reset Integrated Outdoor Sensor

 **Note:** If the sensor does not power up after inserting the batteries, press the reset button as shown in Figure 3.

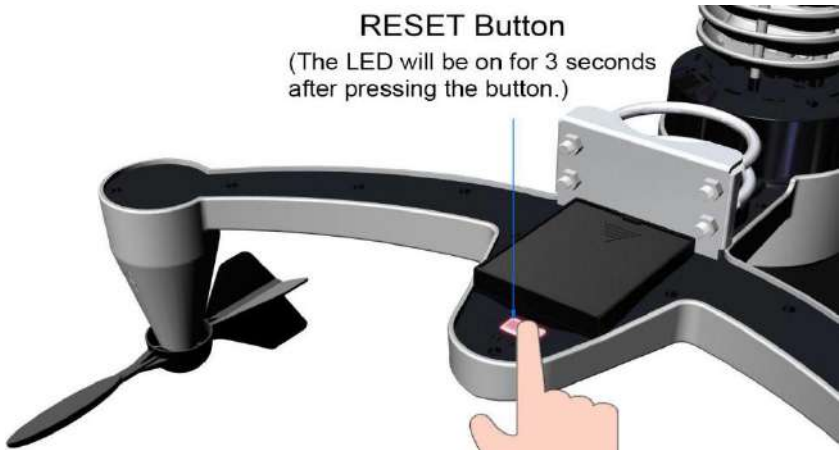

Figure 3

3.4 Display Console

3.4.1 Layout of Display Console

The following illustration shows the full segment LCD display for feature description purposes only in Figure 4, and will not appear like this during normal operation.



Figure 4

3.4.2 Setup the Display Console

1. Plug in the display console with power adapter.

AC ON will display in the time area for three seconds when powered up.

Note: It is recommended to plug in the power adapter to reduce the battery consumption and extend the service life.



2. Display Console Batteries Installation

Remove the battery door on the back of the display, as shown in Figure 5. Install three AAA (alkaline or lithium) batteries. The display will beep once and layout of display will light up for a few seconds to verify all segments are operating properly.

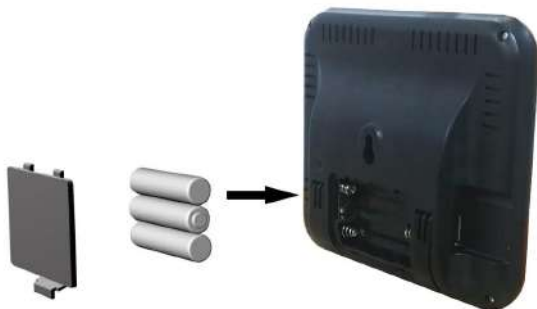



Figure 5



Replace the battery door, and unfold out the desk stand to place the console in the upright position

 **Note:** The battery is a back-up of weather station console, saving console settings when powered off from adaptor

3.4.3 Connect Sensors with Display Console

Once the display console is powered up, it will automatically scan the nearby Integrated Outdoor sensor.

 **Note:** Do not press any button until all the remote sensors report in the display screen, otherwise the display console will terminate to connect with remote sensors.

 **Note:** While in the search mode, the remote search icon  will be constantly displayed until all the measured values received. The console will automatically switch to the normal mode from which all further settings can be performed.

When connected with the Integrated Outdoor Sensor, the measured value (Outdoor temperature, humidity, wind speed, wind direction, wind gust and average, rainfall, dew point and feels like) will show up on the display console.

 **Note:** Make sure that the distance between weather station sensors and display console should be within 10ft (3m) to 100ft (30m). If the weather station sensors is too close or too far away, it may not receive a proper signal.

3.5 Sensor Operation Verification

The following steps verify proper operation of the sensors prior to install the sensor array.

1. **Verify proper operation of the rain gauge.** Tip the Integrated outdoor sensor back and forth several times. You will heard a “ticking” sound within the rain gauge. Verify the

rain reading on the display console is not reading 0.00. Each “ticking” represents 0.01 inch(0.3mm) of rainfall.

2. **Verify proper operating of the wind speed.** Rotate the wind cups manually or with a constant speed fan. Verify the wind speed is not reading 0.0.

3. **Verify proper operation of in/outdoor temperature.** Verify the indoor and outdoor temperature match closely with the console and sensor array in the same location (about 5 to 10’ (1.5 to 3 meters) apart). The sensors should be within 4°F /2°C (the accuracy is $\pm 2^\circ\text{F}/1^\circ\text{C}$). Allow about 30 minutes for both sensors to stabilize.

4. **Verify proper operation of in/outdoor humidity.** Verify the indoor and outdoor humidity. Verify the indoor and outdoor humidity match closely with the console and sensor array in the same location (about 5 to 10’ (1.5 to 3 meters) apart). The sensors should be within 10% (the accuracy is $\pm 5\%$). Allow about 30 minutes for both sensors to stabilize.

4. Sensors Pre-installation

4.1 Test the Sensors Before Installation

Recommend to operate and test the weather station for one week before installing it in the permanent location. In this period, you can check out all of the functions, ensure proper operation, and familiarize with the professional weather station and calibration procedures. This will also allow you to test the wireless range of the weather station.

4.2 Site Survey Before Before Installation

Do a site survey before installing the weather station. Take the following points into Consider:

1. You must clean the rain gauge once per year and change the batteries every two years. Provide as easy access to the weather station.

2. Avoid radiant heat transfer from buildings and structures. In general, install the sensor array at least 5ft (1.5m) from any building, structure, ground, or roof top.

3. Avoid wind and rain obstructions. The rule of thumb is to install the sensor array at least four times the distance of the height of the tallest obstruction. For example, if the building is 20ft (6m) tall, install $4 \times (20 - 6)' = 56\text{ft}$ (17m) away. Use common sense. If the weather station is installed next to a tall building, the wind and rain will not be accurate.

4. Wireless Range. The radio communication between display console and transmitter in an open field can reach a distance of up to 330ft (100m), assume there are no interfering obstacles such as buildings, trees, vehicles, high voltage lines. Wireless radio signals will not penetrate metal buildings. Most wireless applications will only reach up to 100ft (30m) due to building obstructions, walls and interference.

5. Radio interference such as PCs, radios or TV sets can, in the worst case, entirely cut off radio communication. Please take this into consideration when choosing display console or mounting locations.

4.3 Best Practices for Wireless Communication

Wireless communication is susceptible to other interference, such as distance, walls and metal barriers. We recommend the

following best and useful practices for trouble-free wireless communication.

1. **Electro-Magnetic Interference (EMI).** Keep the console several feet away from computer monitors and TVs.

2. **Radio Frequency Interference (RFI).** If you have other 433 MHz devices and communication is intermittent, try turning off these other devices for troubleshooting purposes. You may need to relocate the wireless transmitters or receivers to avoid intermittent communication.

3. **Line of Sight Rating.** This device is rated at 300ft(100m) line of sight (no interference, barriers or walls) but typically you will get 100ft (30m) maximum in most real-world installations, which include passing through barriers or walls.

4. **Metal Barriers.** Radio frequency will not pass through metal barriers such as aluminum siding. If you have metal siding, align the remote and console through a window to get a clear line of sight.

The following is a table of reception loss vs. the transmission medium. Each “wall” or obstruction decreases the transmission range by the factor shown below.

Medium	RF Signal Strength Reduction
Glass (untreated)	5-15%
Plastics	10-15%
Wood	10-40%
Brick	10-40%

Concrete	40-80%
Metal	90-100%

5. Final Installation of Sensors

5.1 Integrated Outdoor Sensor Installation

This Professional Weather Station can be used in both the Northern and Southern Hemispheres. Prior to installation, you will need to calibrate the wind direction.

 **Note:** There are four alphabet letter of N, E, S and W around the wind direction.(N is North, E is East, S is South, W is West)

Northern Hemispheres

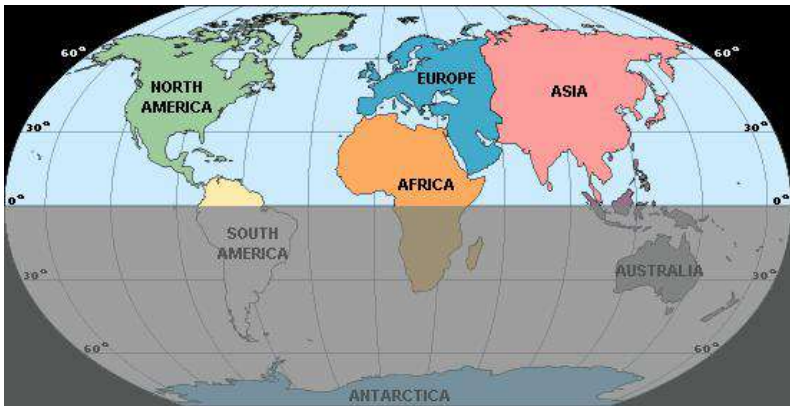

Southern Hemispheres

5.1.1 Northern Hemispheres (NOR) References.

The cardinal directions (N, S, E, W) molded on the body of the outdoor sensor are indicators for the Northern Hemisphere only.

Step 1: There is a “S” indicator on the wind vane that indicates South, as shown in Figure 6. Check the wind directions with compass and Align this “S” marker in the direction of South.

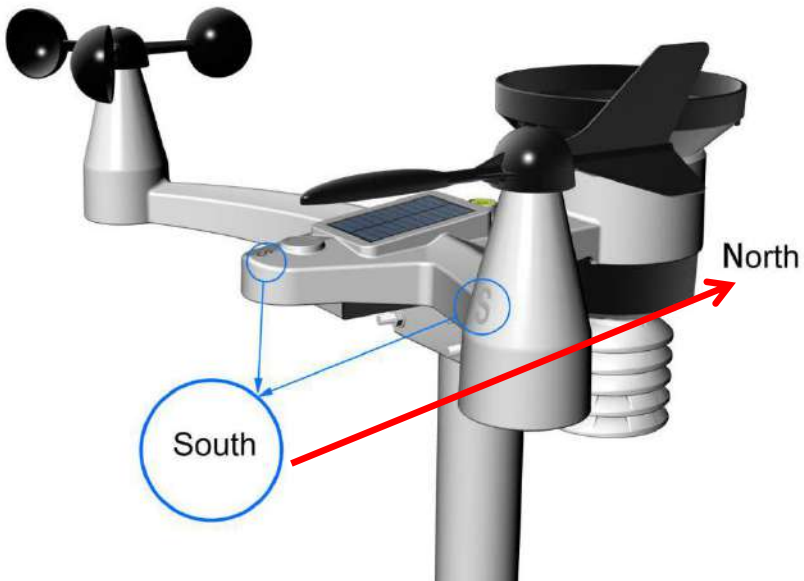

Figure 6

Step 2: Console operation set to Northern Hemispheres(**NOR** in the time area) in Location division. (Check the detailed step of setting the time area in the part 17 of Chapter 7.2)

5.1.2 Southern Hemispheres (NOR) References.

For Southern Hemisphere installations, ignore the direction (N, S, E, W), and face **the solar panel to the North** (and in a sunny position) when it comes to install the Integrated outdoor sensor, as show in figure 7.

Step 1: Install the Integrated outdoor transmitter and face the solar panel to the North.

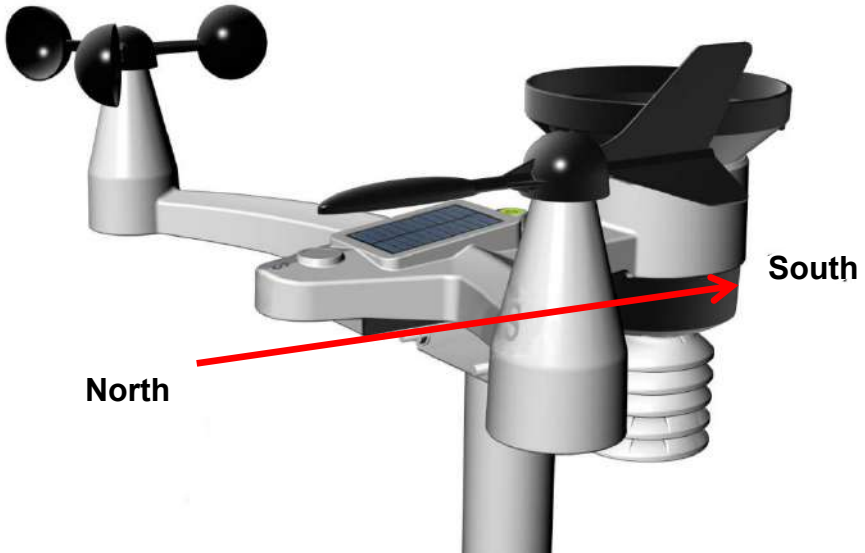



Figure 7

Step 2: Console operation set to Southern Hemispheres(**SOU** in the time area) in Location division. (Check the detailed step of setting the time area in the part 17 of Chapter 7.2)

 **Note:** The location division (NOR or SOU) on the Display Console and the directions of the sensor have to be adjusted to match with your real location. If the wind direction sensor is not positioned correctly during installation, permanent wind direction error will be triggered.

5.1.3 Mounting & Fixing the Sensor

Fasten the integrated outdoor sensor to the mounting pole. U-Bolts accept a mounting pole (not included) diameter of 30-45mm.

1) Insert the iron pipe(Mounting pole) into the U-bolt.

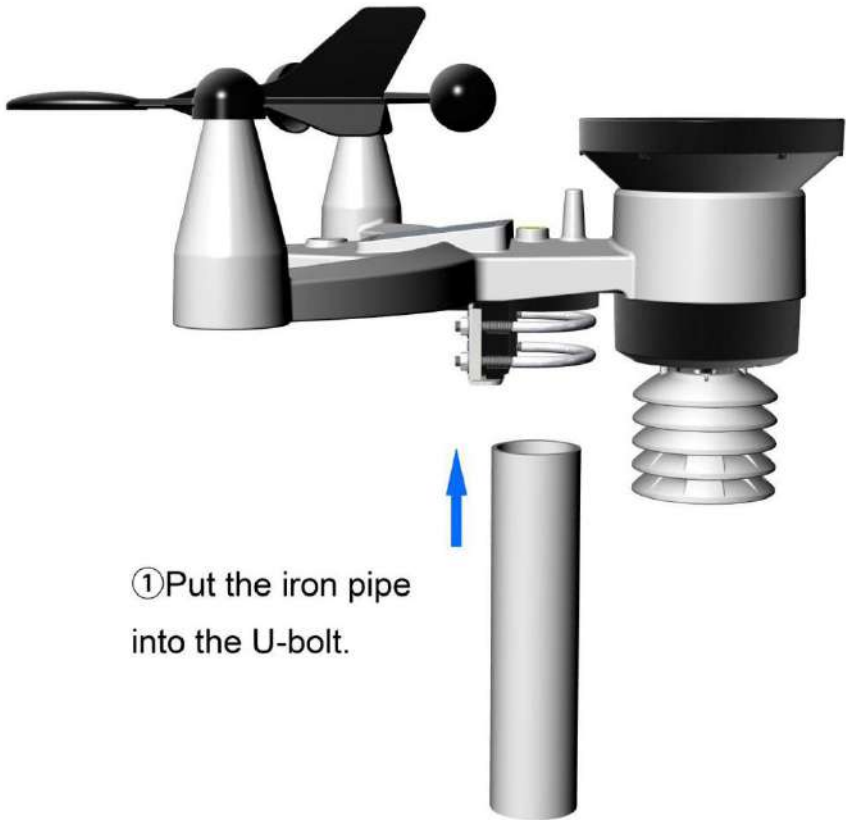

2) Place the washer and the nuts on the U-bolts, and use the wrench to rotate clockwise and tightly.

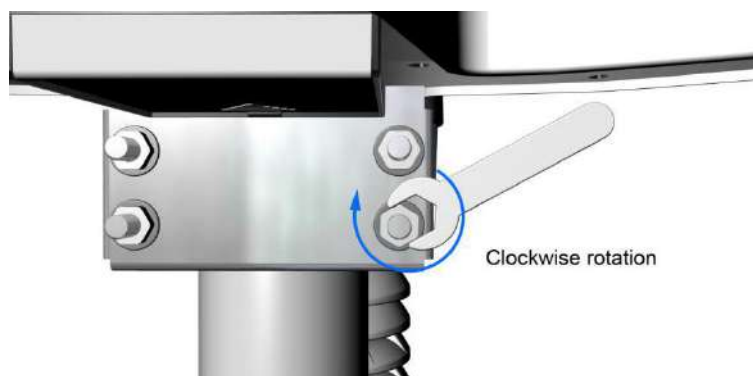
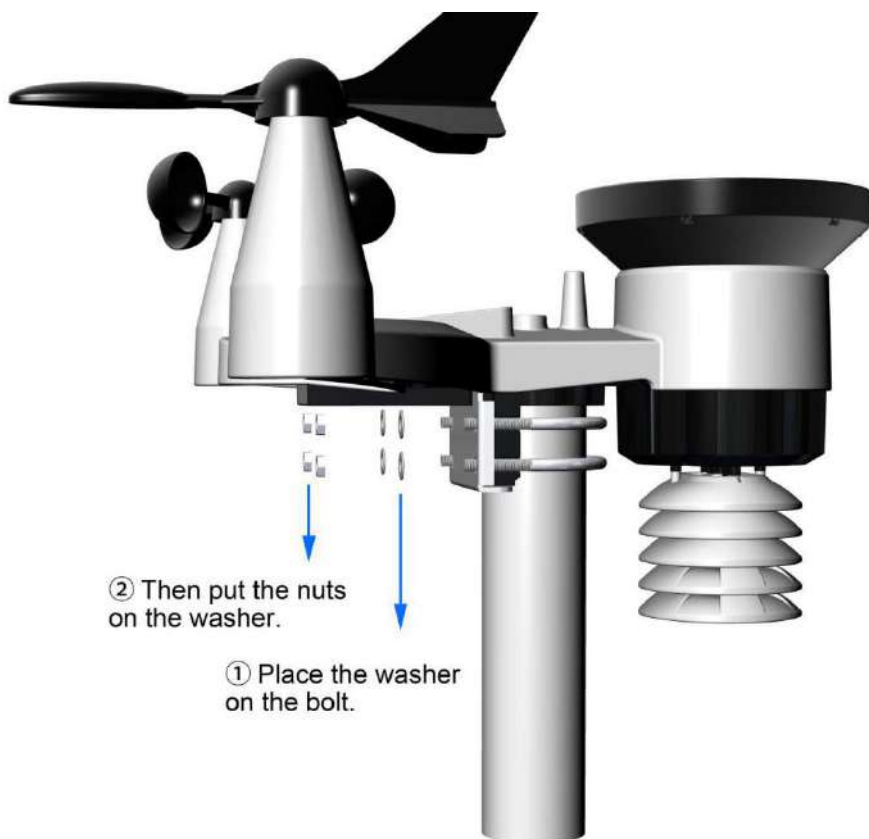

6. Low Battery Icon

A low battery indicator icon is shown in the display window for integrated outdoor sensor(Near the top of out temperature).

When the low battery icon appears (The Integrated outdoor sensor battery voltage is lower than 3.6V), replace the batteries in the sensor with fresh batteries.

Be sure to never mix old and new batteries, and never mix battery types such as alkaline and lithium together.

7. Display Console Operation

7.1 Quick Display Mode



Note: The display console has five keys for easy operation: **HISTORY/-** key, **SET** key, **Max/Min/AL** key, **CHANNEL/+** and **SNOOZE/LIGHT** key.



Note: To exit the Quick Display Mode at any time, press the **SNOOZE** key of the display console.

While in Normal Mode, press (do not hold) the **SET** key to enter the Quick Display Mode as follows:

- ◆ Once for time, time/week and date,
- ◆ Twice for rainfall.
- ◆ Three times for pressure.
- ◆ Four times for 72h or 24h graph record

1. **Time, Time/Week and Date.** Touch the **CHANNEL/+** or **HISTORY/-** key to toggle between time, time/week and date.

2. **Rainfall.** Touch the **CHANNEL/+** or **HISTORY/-** key to toggle between 1h, 24h, week, month and total.

*To clear the total rain, Touch the **CHANNEL/+** or **HISTORY/-** button until total rain is displayed. The total rain will flash. Touch and hold the **SET** button for three seconds until total rain reads 0.00.*

3. **Absolute Pressure and Relative Pressure.** Touch the **CHANNEL/+** or **HISTORY/-** key to toggle between absolute pressure and relative pressure.

4. **72h or 24h Graph Record.** Touch the **CHANNEL/+** or **HISTORY/-** key to toggle between the last -72 hours or -24 hours record time. Each bar represents the corresponding data and time for wind speed, rainfall, pressure, temperature or humidity.(default is -72 hours)

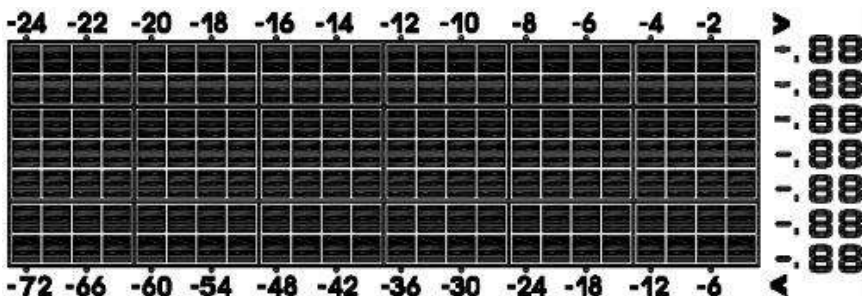



Figure 8

 **Note:** The graph displays hours on the horizontal or x-axis (the most recent data to the right of the graph). For example, 0h is the current data and -12 is 12 hours ago. The vertical axis or y-axis auto-scales, displays the deviation from the current value (the most recent data will always display 0). For example,

when in temperature mode, if the bar displays 0.4, this represents 0.4 degrees higher than the current value.

7.2 Set (Program) Mode

While in Normal Mode, **Press and hold** the **SET** key for at least three seconds to enter the Set Mode. The first setting will begin flashing. You can press the **SET** key again to skip any step, as defined below.

 **Note:** In the Set mode, press the **Channel/[+]** key or **History/[-]** key to change or scroll the value. Hold the **Channel/[+]** key or **History/[-]** for three seconds to increase/decrease rapidly.

 **Note:** To exit the Set mode at any time, press the **SNOOZE/LIGHT** button on the display console.

1. **12/24 Hour Format (default: 24h):** Press the **SET** key again to adjust the 12/24 hour format setting (FMT). Press the **[+]** key or **[-]** key to change between 12 hour and 24 hour format.
2. **Change Hour.** Press the **SET** key again to set the hour. Press the **[+]** key or **[-]** key to adjust the hour up or down. Note the PM icon is present during afternoon hours.
3. **Change Minute.** Press the **SET** key again to set the minute. Press the **[+]** key or **[-]** key to adjust the minute up or down.
4. **Date Format (default: MM-DD):** Press the **SET** key again to enter the day/month format mode. Press the **[+]** key or **[-]** key to switch between MM-DD-YY, DD-MM-YY.

5. **Change Month.** Press the **SET** key again to set the calendar month. Press the **[+]** key or **[-]** key to adjust the calendar month.
6. **Change Day.** Press the **SET** key again to set the calendar day. Press the **[+]** key or **[-]** key to adjust the calendar day.
7. **Change Year.** Press the **SET** key again to set the calendar year. Press the **[+]** key or **[-]** key to adjust the calendar year.
8. **Max/Min Clearing (default: ON).** Press the **SET** key again to set the max/min clearing mode (CLR). The Max/Min can be programmed to clear daily (at midnight) or manually. Press the **[+]** key or **[-]** key to switch between “Clears 24h” and Clears Manually.
9. **Temperature Units of Measure (default: °C):.** Press the **SET** key again to change the temperature units of measure (the **UNITSET** icon will be displayed). Press the **[+]** key or **[-]** key to switch between °F and °C units of measure.
10. **Wind Speed Units of Measure (default: m/s).** Press the **SET** key again to change the wind speed units of measure . Press the **[+]** key or **[-]** key to toggle the wind speed units between m/s, km/h, mph, knots or bft.
11. **Rainfall Units of Measure (default: mm).** Press the **SET** key again to change the Rainfall units of measure. Press **[+]** key or **[-]** key to toggle the rainfall units between mm and inch.
12. **Barometric Pressure Units(default: hPa).** Touch the **SET** key again to change the pressure units of measure. Press the **[+]** key or **[-]** key to toggle the pressure units between mmhg, inHg or hPa.
13. **Pressure Threshold Setting (default level 2).** Press the **SET** key again adjust the Pressure threshold setting (the

WEATHER icon will be displayed). Press **[+]** key or **[-]** key to adjust the pressure threshold setting up or down. **(Refer to Section 10.5 for more details on this function.)**

14. **Storm Threshold Setting (default level 4)**. Press the **SET** key again entering into the storm threshold setting (the **STORM** icon will be displayed). Press the **[+]** key or **[-]** key to adjust the storm threshold up or down. **(Refer to Section 10.4 for more details on this function.)**
15. **Weather Forecast Icon Setting (default: partly cloudy)**. Press the **SET** key again to set the weather forecast icon initial conditions (based on the current weather conditions). Press the **[+]** key or **[-]** key to toggle weather icons between sunny, partly cloudy, cloudy, or rainy.
16. **Record Interval(default: 30Minutes)**. Press the **SET** key again to change the record interval. Press the **[+]** key or **[-]** key to toggle the interval between 16s, 32s, 48s or 1-240min.
17. **Location Division. (default: Northern Hemisphere)**. Press the **SET** key again to change the location division. Press the **[+]** key or **[-]** key to toggle the position of the earth Northern Hemisphere (NOR) or Southern Hemisphere (SOU). **(Refer to 5.0 Final Installation of Sensors)**

7.3 Sensors Search Mode

If Integrated Outdoor Transmitter data is lost, press and hold the **CHANNEL/+** button for 3 seconds, the search icon will be displayed constantly for 3 minutes. Once the signal is reacquired, the remote search icon  will turn off, and the current values will be displayed.

7.4 History Graph Mode

The measured parameters display on the the historical graph.

In normal mode, touch the **HISTORY/-** key to toggle between:

- ◆ Indoor temperature graph (the **TEMP-IN** icon is displayed)
- ◆ Indoor humidity graph (the **HUMI-IN** icon is displayed)
- ◆ Outdoor temperature graph (the **TEMPOUT** icon is displayed)
- ◆ Outdoor humidity graph (the **HUMIOUT** icon is displayed)
- ◆ The wind speed graph (the **WIND** icon is displayed),
- ◆ The rainfall graph (the **RAIN** icon is displayed)
- ◆ The barometer graph (the **BAROREL** icon is displayed)

7.5 Max/Min Viewing and Reset Mode

7.5.1 Max Record Viewing and Reset

In normal mode, press (do not hold) the **MAX/MIN/AL** key, and the **MAX** icon will be displayed. Press the **HISTORY/-** key to view rainfall (1h, 24h, week or month) and pressure (ABS or REL) Max value.

Next, Press the **SET** key for three seconds to clear the rainfall, wind speed, wind gust, pressure, temperature and humidity maximum values. The maximum values will now display the current values.

Press the **MAX/MIN/AL** key again (do not hold), and the **MIN** icon will be displayed. Press the **HISTORY/-** key to view pressure (ABS or REL) min value.

Next, Press the **SET** key for three seconds to clear the pressure, temperature and humidity minimum values. The minimum values will now display the current values.

Press the **SNOOZE/LIGHT** key to exit the min/max checking and reset mode, return to normal display mode.

7.6 Snooze Mode

If the alarm sounds, and you wish to silence the alarm, press the **SNOOZE** key, the backlight will turn on. The alarm icon will continue to flash and the alarm will silence for five minute.

Press any key (**MIN/MAX/AL,HISTORY/-, SET,CHANNEL/+**) to permanently exit the **SNOOZE** mode.

7.7 Backlight Mode

7.7.1 Adjustable Brightness of Backlight

There are 3 levels of brightness of display backlight. When the backlight is on, press **SNOOZE/LIGHT** key to switch between the 3 levels.

When backlight is off, press and hold the **SNOOZE/LIGHT** key for three seconds, the backlight will turn on permanently, and **LED ON** icon will be displayed for three seconds in the date area.

To turn off the display backlight at any time, press and hold the **SNOOZE/LIGHT** key for three seconds.

 **Note:** If the display console plugged into AC adapter power, the time area will display AC ON and the backlight will remain on. It is not recommended leaving the display backlight on for a long period of time when operating on batteries only, or the batteries will run out quickly.

 **Note:** The backlight operation is different when operating on batteries to save power.

If the display console only powered by battery, and backlight is off, Press the **SNOOZE/LIGHT** button once. The backlight will turn on for five seconds, and if no operation is performed for three seconds, the backlight will turn off.

8. Alarm Mode

The weather station includes the following alarms:

- ◆ Time
- ◆ Indoor Temperature
- ◆ Indoor Humidity
- ◆ Outdoor Temperature
- ◆ Outdoor Humidity
- ◆ Outdoor Feels Like Temperature
- ◆ Outdoor Dew Point
- ◆ Wind Speed
- ◆ Wind Gust
- ◆ Indoor Dew Point
- ◆ 1h Rainfall
- ◆ 24 Hour Rainfall
- ◆ Absolute Pressure
- ◆ Relative Pressure

8.1 Alarm Triggered

When an alarm condition is exceeded, the alarm icon will flash  (visual) and the alarm beeper will sound (audible). To silence the beeper, press any key.

8.2 View High/Low Alarms Value

To view the current alarm settings, press and hold the **MIN/MAX/AL** key for three seconds to enter the alarm mode. The **HI** alarms will be displayed along with the alarm clock time.

Press the **MIN/MAX/AL** key to view the **LOW** alarms along with the alarm clock time.

Press the **SET** key to view rainfall (1h and 24h) high alarm and pressure (ABS and REL) high/low alarm.

Press the **SNOOZE/LIGHT** key at any time to return to the normal mode.

8.3 Setting the Alarms

In Alarm Mode, press and hold the **SET** key for three seconds to enter the alarm mode.

Next, Press and hold the **SET** key for three seconds. The first alarm parameter will begin flashing (alarm hour).

To save the alarm setting and proceed to the next alarm parameter, Press (do not hold) the **SET** key.

To adjust the alarm parameter, press the [+] or [-] key to increase or decrease the alarm settings, or press and hold the [+] or [-] key for three seconds to increase or decrease the alarm settings rapidly.

Press the **MIN/MAX/AL** key to turn on (the alarm icon will appear) and off the alarm.

Press the **SNOOZE/LIGHT** key twice at any time to return to the normal mode. After 30 seconds of inactivity, the alarm mode will time out and return to normal mode.

The following is a list of the individual alarm parameters that are set (in order):

- | | |
|----------------------------------|----------------------------------|
| 1.Alarm hour(alarm 1) | 12.Outdoor feels like low alarm |
| 2.Alarm minute(alarm 1) | 13.Outdoor dew point high alarm |
| 3.Rainfall (1h) high alarm | 14.Outdoor dew point low alarm |
| 4.Rainfall (24h) high alarm | 15.Absolute pressure high alarm |
| 5.Wind Gust high alarm | 16.Absolute pressure low alarm |
| 6.Wind Average high alarm | 17.Relative pressure high alarm |
| 7.Outdoor temperature high alarm | 18.Relative pressure low alarm |
| 8.Outdoor temperature low alarm | 19.Indoor temperature high alarm |
| 9.Outdoor humidity high alarm | 20.Indoor temperature low alarm |
| 10.Outdoor humidity low alarm | 21.Indoor humidity high alarm |
| 11.Outdoor feels like high alarm | 22.Indoor humidity low alarm |

 **Note:** To prevent repetitive temperature alarming, there is a 0.9 °F(0.5°C) tolerance band. For example, if you set the high alarm to 80.0 °F(26.7°C) and silence the alarm, the alarm icon will continue to flash until the temperature falls below 80.0°F (26.7°C), at which point, the alarm will reset and must increase above 80.0 °F(26.7°C) to activate again.

 **Note:** To prevent repetitive alarming of humidity, there is a 4% tolerance band in humidity alarm. For example, if you set the high alarm to 60% and silence the alarm, the alarm icon will continue to flash until the humidity falls below 56%, at which point, the alarm will reset and must increase above 60% to activate again.

8.4 Alarm and Key Beeper ON/OFF

Press any button to silence the alarm sound.

In normal mode, press and hold the **HISTORY/-** key for three seconds to toggle the beeper on or off (depending on the current setting). The BUZZ ON (beeper on) or BUZZ OFF (beeper off) icon will appear in the time area for three seconds.

Display console return to normal mode without any operation in three seconds.

9. Optional Calibration Mode



Note: The calibrated value can only be adjusted on the display console. The outdoor remote sensor(s) always displays the un-calibrated or measured value.



Note: The measured humidity range is between 10% and 99%. Humidity cannot be accurately measured outside of this range. Thus, the humidity cannot be calibrated below 10% or above 99%.

The purpose of calibration is to fine tune or correct for any sensor error associated with the devices margin of error. The measurement can be adjusted from the console to calibrate to a known source.

Calibration is only useful if you have a known calibrated source you can compare it against, and is optional. This section discusses practices, procedures and sources for sensor calibration to reduce manufacturing and degradation errors. Do not compare your readings obtained from sources such as the internet, radio, television or newspapers. They are in a different location and typically update once per hour.

The purpose of your weather station is to measure conditions of your surroundings, which vary significantly from location to location.

9.1 Calibration of Temperature Mode

In normal mode, press and hold the **SET** and **CHANNEL/+** keys at the same time for five seconds to enter the indoor temp calibration mode. The indoor temperature will begin flashing.

Press the **CHANNEL/+** key or **HISTORY/-** key to increase or decrease the temperature reading (in increments of 0.1). Press and hold the **CHANNEL/+** key or **HISTORY/-** key for three seconds to increase or decrease rapidly.

Press the **MAX/MIN/AL** key to reset current value.

Press the **SET** key switch to outdoor temp calibration mode.

To exit the temperature calibration mode at any time, press the **SNOOZE/LIGHT** button on the top of the display console. If no operation is performed, the calibration mode will timeout in 30 seconds.

9.2 Calibration of Humidity Mode

In normal mode, press and hold the **SET** and **HISTORY/-** keys at the same time for five seconds to enter into the humidity calibration mode. The indoor humidity will begin flashing.

Press the **CHANNEL/+** key or **HISTORY/-** key to increase or decrease the humidity reading (in increments of 1%). Press and hold the **CHANNEL/+** key or **HISTORY/-** key for three seconds to increase or decrease rapidly.

Press the **MAX/MIN/AL** key to reset current value.

Press the **SET** key switch to outdoor humidity calibration mode.

To exit the humidity calibration mode at any time, press the **SNOOZE/LIGHT** button on the top of the display console. If no operation is performed, the calibration mode will timeout in 30 seconds.



Note: The Humidity is a difficult parameter to measure accurately and drifts over time. The calibration feature allows you to zero out this error. To calibrate humidity, you will need an accurate source, such as a sling psychrometer or Humidipaks One Step Calibration kit.

9.3 Calibration of Sensors Mode

In normal mode, press and hold the **SET** and **MAX/MIN/AL** keys at the same time for five seconds to enter the pressure, wind gust, rainfall mode. The letter “CORRECT” will appear at the bottom of the screen.

Press the **SET** key to skip over a parameter to the next.

◆ Wind Speed Calibration

In the calibration mode, the wind speed value will flash (the default is 1.00).

Press the **CHANNEL/+** key or **HISTORY/-** key to adjust the wind speed calibration factor from 0.75 to 1.25, where:

Calibrated Wind Speed = Calibration factor x Measured Wind Speed

Press and hold the **CHANNEL/+** or **HISTORY/-** key for three seconds to increase or decrease rapidly.

Press the **MAX/MIN/AL** key to reset current value.



Note: The wind gust is also affected by the wind speed calibration factor.



Discussion: Wind speed and wind gust are adversely affected by installation constraints. The rule of thumb is to install the weather station four times the distance of the height of the tallest obstruction (for example, a 6m(20ft) house would require an installation 24m(80ft) away).

In many instances, due to trees and other obstructions, this is not possible. The wind speed calibration allows you to correct for these obstructions.

In addition to installation challenges, wind speed bearings (any moving part) wears over time. To correct for wear, the correction value can be increased until the wind cups must be replaced.

Without a calibrated source, wind speed is a difficult parameter to measure. We recommend using a calibrated wind meter and constant, high speed fan.

◆ **Wind Direction Calibration**

In the calibration mode, press the **SET** button again and the wind direction value will flash (the default is 0).

Press the **CHANNEL/+** key or **HISTORY/-** key to adjust the wind direction calibration factor from -180 to 180.

Press and hold the **CHANNEL/+** or **HISTORY/-** key for three seconds to increase or decrease rapidly.

Press the **MAX/MIN/AL** key to reset current value.



Note: The direction calibration purpose is to re-correct the wind vane direction point to North(In Northern Hemisphere) or point to South(In Southern Hemispheres).

◆ **Rain Calibration**

In the calibration mode, press the **SET** button again and the rain value will flash (the default is 1.00).

Press the **CHANNEL/+** key or **HISTORY/-** key to adjust the rain calibration factor from 0.75 to 1.25, where:

Calibrated Rain = Calibration factor x Measured Rain

Press and hold the **CHANNEL/+** or **HISTORY/-** key for three seconds to increase or decrease rapidly.

Press the **MAX/MIN/AL** key to reset current value.



Discussion: The rain collector is calibrated at the factory based on the funnel diameter. The bucket tips every 0.01” of rain (referred to as resolution). The accumulated rainfall can be compared to a sight glass rain gauge with an aperture of at least 4”.



Note: that debris and insects can collect inside the tipping mechanism (they make a good spiders nest). Carefully remove the funnel and inspect the tipping mechanism for debris prior to calibration.

◆ **Absolute Pressure Calibration**

In the calibration mode, press the **SET** button again, the “ABS” symbol will display at the pressure section, the absolute pressure value will flash. (The default value is 0.00 inHg)

Press the **CHANNEL/+** key or **HISTORY/-** key to increase or decrease the absolute pressure value (in increments of 0.01 inHg).

Press and hold the **CHANNEL/+** or **HISTORY/-** key for three seconds to increase or decrease rapidly.

Press the **MAX/MIN/AL** key to reset current value.

Example: The calibrated pressure sources measure 28.37 inHg. The display console pressure reads 28.75 inHg.
Offset = $28.37 - 28.75 = -0.38$ inHg

◆ Relative Pressure Calibration

In the calibration mode, press the **SET** button again, the “REL” symbol will display at the pressure section, the relative pressure value will flash. (The default value is 0.00 inHg)

Press the **CHANNEL/+** key or **HISTORY/-** key to increase or decrease the relative pressure value (in increments of 0.01 inHg).

Press and hold the **CHANNEL/+** or **HISTORY/-** key for three seconds to increase or decrease rapidly.

Press the **MAX/MIN/AL** key to reset current value.

Example: The calibrated pressure sources measure 25.00 inHg. The display console pressure reads 24.85 inHg.
Offset = $25.00 - 24.85 = 0.15$ inHg

To exit the sensor calibration mode at any time, press the **SNOOZE/LIGHT** button on the top of the display console. If no operation is performed, the calibration mode will timeout in 30 seconds.



Note: The display console displays two different pressures: absolute (measured) and relative (corrected to sea-level).

To compare pressure conditions from one location to another, meteorologists correct the pressure to sea-level conditions. Because the air pressure decreases as you rise in altitude, the sea-level corrected pressure (the pressure your location would

be at if located at sea-level) is generally higher than your measured pressure.

Thus, your absolute pressure may read 28.62 inHg (969 mb) at an altitude of 1000 feet (305 m), but the relative pressure is 30.00 inHg (1016 mb).

The standard sea-level pressure is 29.92 in Hg (1013.2hpa). This is the average sea-level pressure around the world. Relative pressure measurements greater than 29.92 inHg (1013.2hpa) are considered high pressure and relative pressure measurements less than 29.92 inHg are considered low pressure.

To determine the relative pressure for your location, locate an official reporting station near from you (the internet is the best source for real-time barometer conditions, such as the website of Weather.com or Wunderground.com), and set your weather station to match the official reporting station.



10. Other Features of Display Console



10.1 Weather Forecasting

 **Note:** The weather forecast or pressure tendency is based on the rate of change of barometric pressure. In general, when the pressure increases, the weather improves (sunny to partly cloudy) and when the pressure decreases, the weather degrades (cloudy to rain).

The weather forecast is an estimation or generalization of weather changes in the next 24 to 48 hours, and varies from location to location. The tendency is simply a tool for projecting weather changing conditions and is never to be relied upon as an accurate method to predict the weather.

10.2 Weather Icons

Condition	Icon	Description
Sunny		Pressure is rising and the previous condition is partly cloudy.
Stars and Moon		On a sunny day, between 7:00pm and 7:00am (night time), the stars will be displayed instead of the sunny icon.
Partly Cloudy		Pressure is falling and the previous condition is sunny or Pressure is rising and the previous condition is cloudy.

<p>Cloudy</p>		<p>Pressure is falling and the previous condition is partly cloudy or Pressure is rising and the previous condition is rainy.</p>
<p>Rainy</p>		<p>Pressure is falling and the previous condition is cloudy</p>

10.3 Moon Phase

The following moon phases are displayed based on the calendar date.

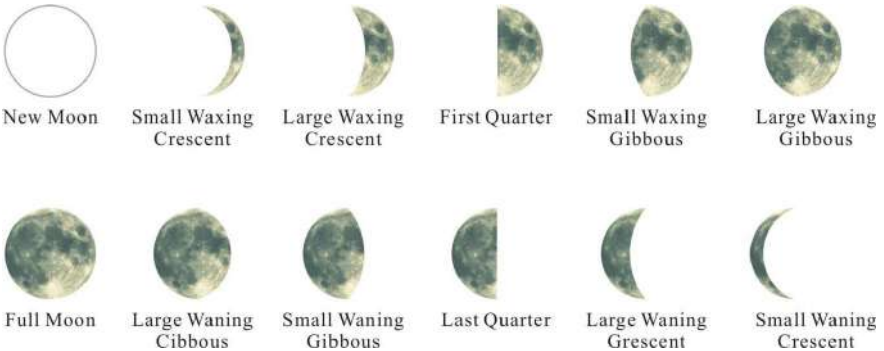

10.4 Storm Threshold Indication

The storm threshold (the negative rate of pressure change signifying a storm is expected) can be adjusted from 3 mbar/hour to level 9 mbar/hour (the default level 4 mbar/hour). The lower the level pressure threshold setting, the higher sensitivity for weather forecast changes. Locations that experience frequent changes in air pressure require a higher setting compared to locations where the air pressure is typically stagnant.

10.5 Pressure Threshold Setting

The pressure threshold (the negative or positive rate of change of pressure signifying a change in the weather) can be adjusted from 2 mbar/hour to 4 mbar/hour (default level 2 mbar/hour).

The lower the level pressure threshold setting, the higher sensitivity for weather forecast changes. Locations that experience frequent changes in air pressure require a higher setting compared to locations where the air pressure is typically stagnant.

10.6 Feels Like Temperature

Feels like temperature is a combination of Heat Index and Wind Chill.

1. Temperatures less than 4.4°C(40°F), the wind chill is displayed, as shown in the National Weather Service Wind Chill Table below:



NWS Windchill Chart

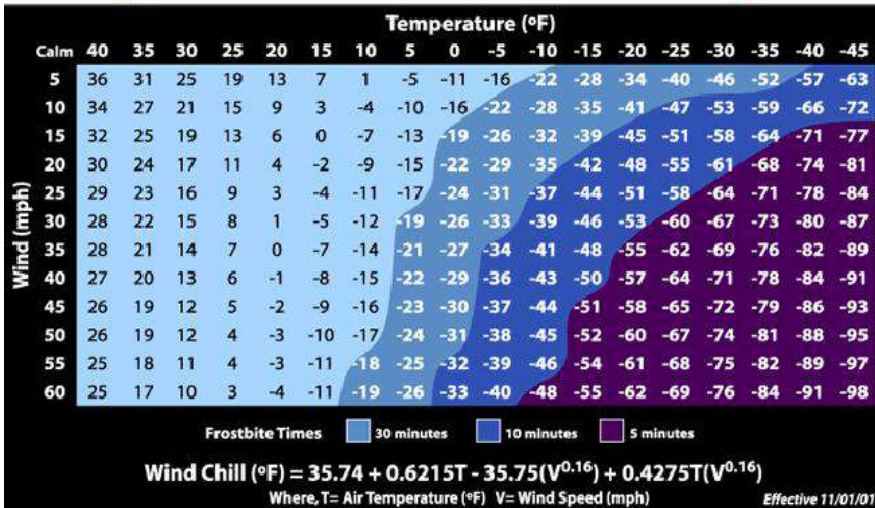

2. Temperatures greater than 26.7°C(80°F), the heat index is displayed, as shown in the National Weather Service Heat Index Table below:

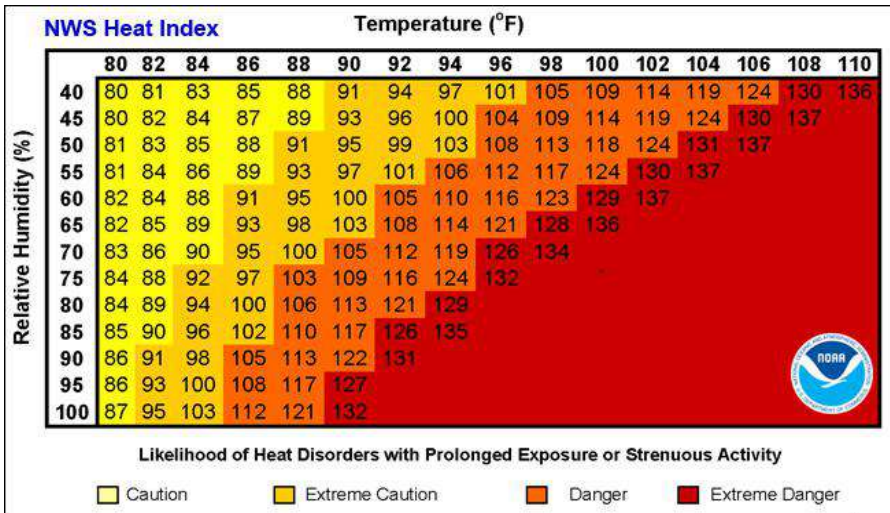

10.7 Restore Factory Default

To reset the display console to factory default (display), press the **MAX/MIN/AL** key while plugging in power adaptor at the same time (Take out batteries before starting the reset operation).

11. PC Software

 **Note:** WeatherHome software disk is included within the weather station package. ***The software only runs on Windows PC operating systems.***

1. To install the **"WeatherHome"** software in your PC, the minimum requirements are as follows:

Operating System: Windows NT4 (Service Pack >= 6a), Windows 2000, Windows Vista, Windows 7-10.

PC: Internet Explorer 6.0 or above; Processor: Pentium III 500 MHz or above; **Memory:** at least 128MB, 256MB.

Base Station and PC must be connected by USB cable

2. Copy and Install the **"WeatherHome"** software from the disk.

 **Note:** If you can not install the software successfully, please contact your seller.

11.1 Weather Home Software Installation

 **Note:** Close *anti-virus software* on the computer before installing the Weatherhome software to avoid installation failure.

Run **WeatherHome.exe** file according to software installation procedure. The software will install into the program files directory.

After installing the “WeatherHome”, your PC can display all indoor data as well as the weather data from the Base Station received from the external sensors. For operation, simply use the USB cable supplied and connect the Base Station to the PC. From now on you can start to track current and history weather information at your finger tips.



11.2 WeatherHome Software Features

To run WeatherHome Software, in Windows system, select Start -> All Programs -> Weather home.

11.2.1 The following section outlines the features available in the Weather home Software. The main display shows current weather conditions and historical graph.

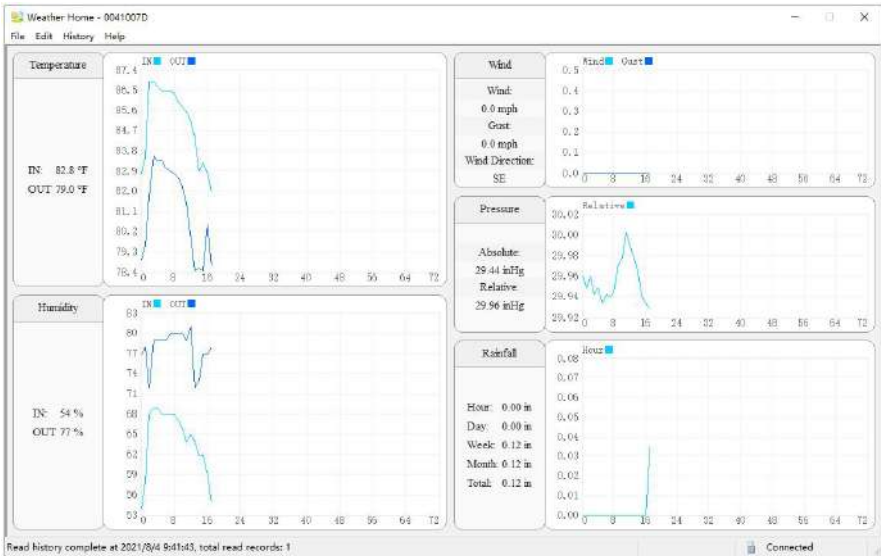

 **Note:** Click the color square icon to display (or not display) the graph data of corresponding parameter

When console is connected to PC, USB Connected icon

 **Connected** will display on the right bottom.

11.2.2 Language Option

Select **Edit | Language** from the menu bar to change the language settings.

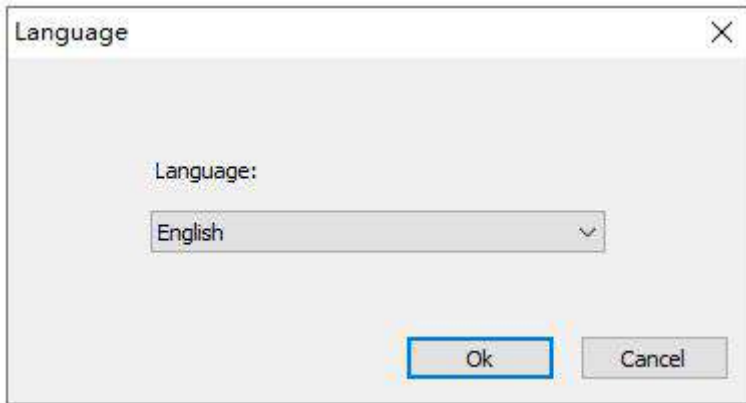

11.2.3 Setting

Select **Edit | Settings** from the menu bar to change general settings including units of measure, data records interval, general display parameters, and backlight.

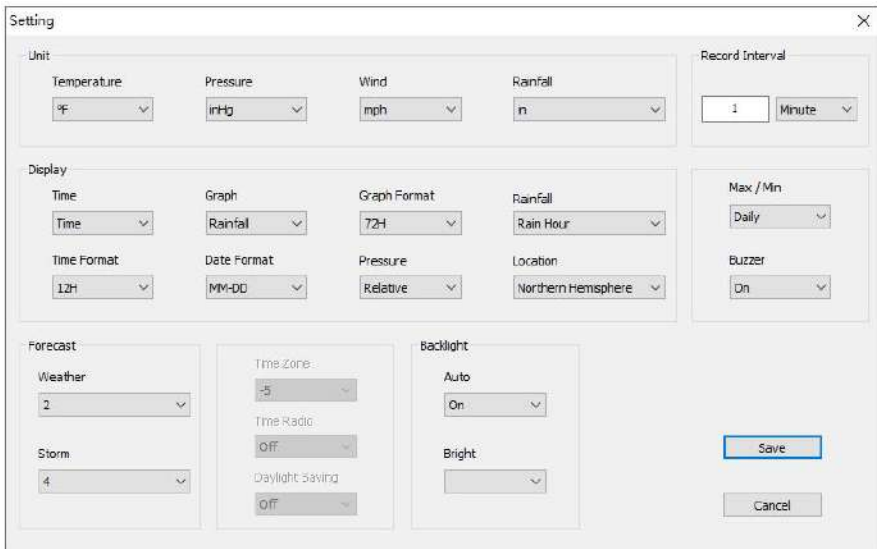

11.2.4 Alarm Values

Select **Edit | Alarm** from the menu bar to program and set the Hi/Low alarm value.

The Alarm configuration window is titled "Alarm" and contains the following settings:

	High	Low
Indoor Temperature	<input type="checkbox"/> 68.0 °F	<input type="checkbox"/> 32.0 °F
Indoor Humidity	<input type="checkbox"/> 65 %	<input type="checkbox"/> 35 %
Outdoor Temperature	<input type="checkbox"/> 86.0 °F	<input type="checkbox"/> 14.0 °F
Outdoor Humidity	<input type="checkbox"/> 75 %	<input type="checkbox"/> 45 %
Dew Point	<input type="checkbox"/> 50.0 °F	<input type="checkbox"/> 14.0 °F
Feels Like	<input type="checkbox"/> 66.0 °F	<input type="checkbox"/> 32.0 °F
Absolute Pressure	<input type="checkbox"/> 30.71 inHg	<input type="checkbox"/> 28.35 inHg
Relative Pressure	<input type="checkbox"/> 30.71 inHg	<input type="checkbox"/> 28.35 inHg

Additional settings on the right side:

	High
Wind	<input type="checkbox"/> 11.2 mph
Gust	<input type="checkbox"/> 22.4 mph
Rain Hour	<input type="checkbox"/> 0.04 in
Rain Day	<input type="checkbox"/> 1.97 in
Alarm Time	<input type="checkbox"/> 0:00

Buttons: Save, Cancel

11.2.5 Historical Min/Max

Select **Edit | Max/Min** from the menu bar to view the historical highs and lows.

The Max / Min window displays historical data for various parameters:

Parameter	Max	Min
Indoor Temperature	87.1 °F	82.8 °F
Indoor Humidity	69 %	54 %
Outdoor Temperature	83.9 °F	78.9 °F
Outdoor Humidity	81 %	69 %
Dew Point	76.6 °F	68.2 °F
Feels Like	93.3 °F	78.9 °F
Absolute Pressure	29.46 inHg	29.41 inHg
Relative Pressure	29.98 inHg	29.93 inHg
Wind	0.0 mph	0.0 mph
Rain Hour	0.00 in	0.00 in
Rain Day	0.00 in	0.00 in
Rain Week	0.12 in	0.12 in
Rain Month	0.12 in	0.12 in

Legend: Max: ■ Min: ■ Daily Max/Min

Buttons: Reset, Exit

11.2.6 Historical Data

Select **History | View** from the menu bar to view the historical data of **Temperature, Humidity, Pressure, wind and rainfall**.

This window displays the recorded history data in a spreadsheet format. If you want to see all history data in a specified time period, enter the time duration (Start Time and End Time) and press **update** to reload the historical data.

You can export the selected historical data into a text format file (.CSV or .PDF) by selecting the Export button.

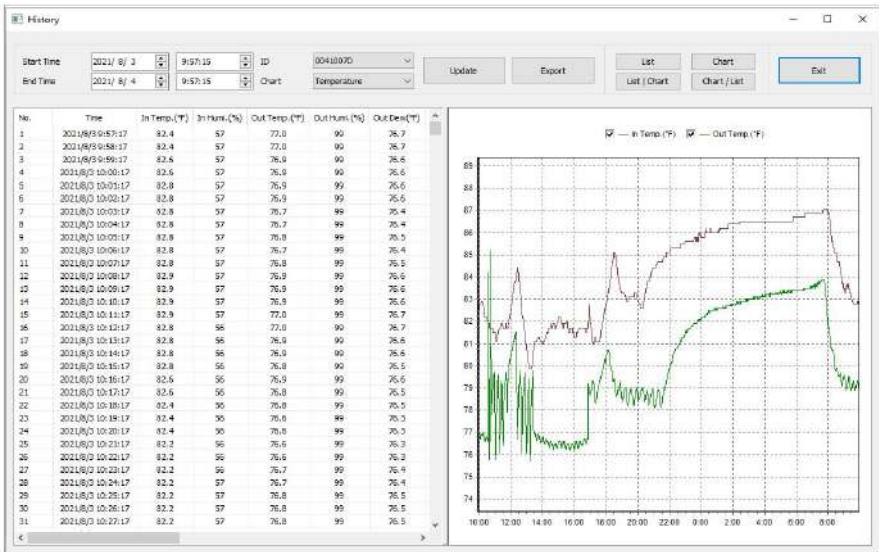

11.2.7 Graph Data

Select **Chart, list/Chart** and **Chart/list** button to view the graphical data.

This window displays the recorded history data in a graphical format. If you want to see all history data in a specified time period, enter the time duration (Start Time and End Time) and press update to reload the graphical data.

 **Note:** Click the selectable icon to display (or not display) the graph data of corresponding parameters.

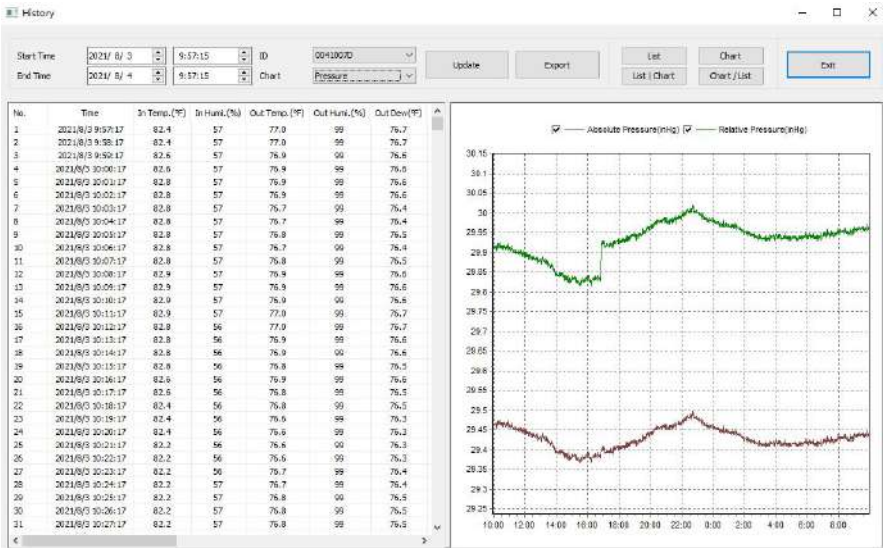

11.2.8 Clear Console Memory and PC database

Select **History | History Manage** from the menu bar to clear the historical data .

When memory on the console is full, select the **History/-** button and power up the console simultaneously to clear memory of the display console.

If you want to start a new weather history record, select the Clear button of **Database** to clear the data, and all historical weather data will be deleted (remember to download (export) all of the recorded data before pressing this button).

 **Note:** The Console and PC software is data synchronous storage. The display console will record approximately 5000 sets of history data circularly and constantly. The PC software will update and record the history data constantly.

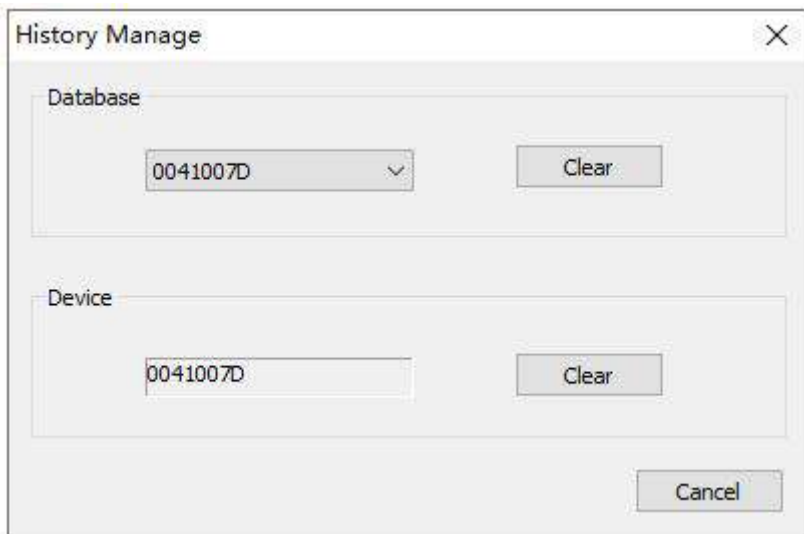

12. Trouble Shooting Guide

Problem	Solution
---------	----------

<p>Wireless remote not reporting in to console.</p> <p>There are dashes (---) on the display console.</p>	<p>If the sensor communication is lost, dashes (---) will be displayed on the screen. To reacquire the signal, press and hold the CHANNEL/+ button for 3 seconds. Once the signal is reacquired, the remote search icon will turn off, and the current values will be displayed.</p> <p>The maximum line of sight communication range is 100 m (330ft) and 30m(100ft) under most conditions. Move the sensor assembly closer to the display console.</p> <p>If the sensor assembly is too close (less than 1.5m(5ft)), move the sensor assembly away from the display console.</p> <p>Install a fresh set of batteries in the remote sensor. For cold weather environments, install lithium batteries.</p> <p>Make sure the remote sensors are not transmitting through solid metal (acts as an RF shield), or earth barrier (down a hill).</p> <p>Move the display console around electrical noise generating devices,</p>
---	--

	<p>such as computers, TVs and other wireless transmitters or receivers.</p> <p>Move the remote sensor to a higher location. Move the remote sensor to a closer location.</p>
Indoor and Outdoor Temperature do not agree	<p>Allow up to one hour for the sensors to stabilize due to signal filtering. The indoor and outdoor temperature sensors should agree within 2°C(4°F) (the sensor accuracy is ± 1°C(2°F)).</p> <p>Use the calibration feature to match the indoor and outdoor temperature to a known source.</p>
Indoor and Outdoor Humidity do not agree	<p>Allow up to one hour for the sensors to stabilize due to signal filtering. The indoor and outdoor humidity sensors should agree within 10 % (the sensor accuracy is ± 5 %).</p> <p>Use the calibration feature to match the indoor and outdoor humidity to a known source.</p>

13. Specification

13.1 Measurement Specifications

The following table provides specifications for the measured parameters.

Measurement	Range	Accuracy	Resolution
Indoor Temperature	0 to 60 °C (32 to 140°F)	± 1 °C (± 2°F)	0.1 °C(°F)
Outdoor Temperature	-40 to 60 °C (-40 to 140°F)	± 1 °C (± 2°F)	0.1 °C(°F)
Indoor Humidity	10 to 99 %	± 5% (only guaranteed between 20 to 90%)	1 %
Outdoor Humidity	10 to 99%	± 5% (only guaranteed between 20 to 90%)	1 %
Rain	0 to 9999mm	<15mm: ±1 mm, 15mm to 9999mm: ±7%	<1000mm (0.3mm) >1000mm (1mm)
Wind Direction	0 - 360°	± 10° (8 point compass)	± 1° (8 point compass)
Wind Speed	0 to 50 m/s	2 m/s ~10 m/s:±0.3m/s , 10m/s ~50	0.1 m/s

		m/s: $\pm 10\%$ (whichever is greater)	
Barometric Pressure:	300 to 1100 hpa	± 3 hpa	0.1 hpa

13.2 Wireless Specifications

Wireless Transmit Range (in open air):	330ft (100m)
Frequency:	433MHz
Integrated Outdoor Sensor Data Update Period:	16s

13.3 Power Consumption

Display Console	3 x AAA 1.5V Alkaline or Lithium batteries (not included)
Integrated Outdoor Sensor:	3xAA alkaline batteries or Lithium batteries (not included), the batteries provide backup power when there is limited solar energy. Note: Solar panel doesn't charge the battery and it is an auxiliary power supply
Adapter:	5.9V~500mA(included)
Battery life:	Minimum 12 months for sensors (use lithium batteries in cold weather climates less than -20°C (-4°F).