

CONTINUATION

Dear User,

Description in the manual is based on the newest products. Owing to improvement or other changes, contents of manual may differ from practical situation. Our company will reserve the right of recension at any moment. Please kindly forgive not to notify the revised places one by one.

The copyright of this manual belongs to Wenzhou Sundoo Instruments Co., Ltd. Any companies or individuals have no rights to copy or plagiarize part or whole contents of the manual without permission of our company.

制造商：温州山度仪器有限公司

MANUFACTURER: WENZHOU SUNDOO INSTRUMENTS CO.,LTD

地址：温州高新技术产业园区10区E幢

Add: Building E, No.10 High-tech Industrial Zone Wenzhou China

Zip: 325013

Tel: +86 577 88609905 Fax: +86 577 88390155

Http://www.sundoo.com E-mail: export@sundoo.com

Ver:3.00 Con:20150926

ST SERIES USER'S MANUAL

ST Series
User Manual

数字式扭矩测试仪
DIGITAL TORQUE METER

For
ST-1
ST-2
ST-5
ST-10
ST-20



温州山度仪器有限公司
WENZHOU SUNDOO INSTRUMENTS CO., LTD

Packing List

Item	Parts name	Quantity
1	Main Body	1
2	Power adaptor	1
3	Torque buffer assembly	1
4	Torque buffer connecting axis	4
5	Torque buffer spring	1
6	M4×12 crossed discal head screw+M4 Nut	1
7	1.5 inter-angle spanner	1
8	Buffer screw	2
9	Straight-through RS232 Cable with Two-sided Holes	1
10	Software CD	1
11	Manual	1
12	Factory Inspection Report	1
13	Qualification Card	1

Thanks very much for your patronage to purchase ST Series Digital Torque Meter.

It is an intelligent multi-function measurement instrument, and can be used for testing various toqure. Before using it, please reading this manual carefully in order to take full advantage of this instrument all functions and get correct torque value.

CONTENTS

- Specification and Parameter1
- Function.....2
- Main Characteristics.....2
- Work Environment.....2
- Parts and Functions.....3
- Operation Process.....6
- Test Process of Screwdriver Torque.....8
- Torque Measuring Head and Connection Dimension.....8
- Buffer's Teat Range, Installment and Inspection.....9
- Port Output and Print.....10
- Rechargeable Battery.....12
- Cautions and Maintenance.....13
- Packing List.....14

- Cautious:
- 1、Frequent and long-playing charging will shorten battery life.
 - 2、Please charge when the battery only has a grid or less a grid power to avoid not to charge fully because of very low power.
 - 3、Charge the battery fully at least once three months.

Cautions and Maintenance

1. Do not apply a torque above the capacity, otherwise the meter may be damaged, even danger will happen;
2. Do not hit or put something on the LCD;
3. Do not press the button with nail, pointed tool or objects;
4. Do not use the meter near water, oil or other liquids. Keep the meter in a dry, shady and stable place;
5. Do not open the rear cover or adjust the resistance;
6. Do not loose the fixed screw on the torque measuring head;
7. Use matched charger, or electric break-down or fire will happen;
8. Before using it please insert the AC charger in the socket completely. Lose plug may lead to fire or electric shocks caused by short circuit;
9. Do not use power exceeding the capacity of charger, or electric shock or fire may happen;
10. Do not plug in or out with wet hand to avoid electric shock;
11. Clean the gauge with soft cloth. First put the dry cloth in the water with detergent and then dry the cloth and clean the meter. Do not use volatile chemical substance such as volatile oil, thinner, alcohol, etc;
12. Handle carefully while carrying and using the meter;
13. Do not disassemble, repair or modify the meter yourself, which may cause permanent fault of the meter;
14. If there is something wrong with the meter, please contact the original sales department or our company.

- G. After setting the parameters, please click "Record Measuring values" option, and switch to curve display interface.
 - H. After clicking start button "▶", then click "TIMER" (🕒) to collect test data curve (See Picture 12).
 - I. After finishing test, please click stop button "■" to stop testing(See Picture 13 on Page 12).
 - J. Click save button to save the data.
 - K. If you choose the Text File, it means that you can import the stored data of the meter. Please choose the matched model and corresponding serial port, then click the start button "▶" to open the serial port and press "▶" on the meter to import the stored data to the computer (See Picture 14).
- Icon instruction

- "📄": The collection data is imported into EXCEL file;
- "▶": Open serial port to start test;
- "■": Close serial port to stop test;
- "📄": Collect current value manually;
- "🕒": Collect the data continuously and regularly.

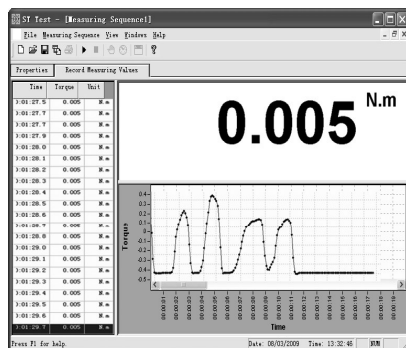

Picture 13

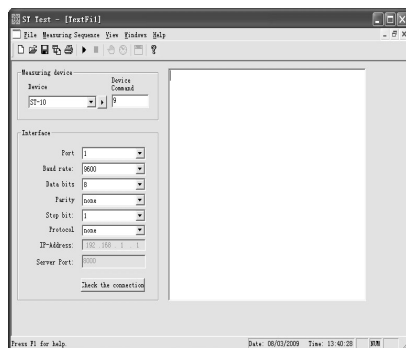

Picture 14

Rechargeable Battery

During using the gauge, if the mark "🔋" flicker, it means that the battery is very low and need to be charged. Please use matched "DC 12V/400mA" charger. With smart charging technology, it will stop charging automatically after charging fully. Practically protect the battery durability.

Specification and Parameter

Model	ST-20	ST-10	ST-5	ST-2	ST-1								
Capacity	20N.m	10N.m	5N.m	2N.m	1N.m								
Resolution	0.01N.m	0.005N.m	0.002N.m	0.001N.m	0.0005N.m								
Accuracy	±0.5%FS												
Peak Collection Frequency	2000 HZ												
Test Speed	≤3000rpm												
Unit	N.m, kgf.cm, lbf.in												
Sensor Type	Sensor Inside												
Power	Adaptor: DC 12V/300mA Rechargeable battery inside: Ni-MH 8.4V 1200mAh												
Use Time	Continuous use for about 16 hours												
Standby Time	About 3 months												
Battery Life	≥300 times												

Function

ST Series Digital Torque Meter is an intelligent multi-function measurement instrument and can be used for testing various torque. It is mainly used for testing and calibrating the torque of various electric/ pneumatic screwdriver (speed is less than 3000rpm)/torque driver/torque wrench. It is also used for testing tightening force of other products and destructive test of parts torsional.

It has high accuracy, easy to operate and handy to carry out, which are widely used in electric, light industry, machinery manufacture, scientific research, and so on.

Main characteristics

1. High accuracy and high resolution.
2. Free setting and judgment of upper and lower limit deviation value, red/green indication lamps and buzzer can alarm automatically with sound and light.
3. Torque Direction display.
4. Blue Background light.
5. Store and print 10 groups test value.
6. Real-time printing of single time test curve.
7. Calculate the average of stored data automatically.
8. Convert three units (N.m, kgf.cm , lbf.in) automatically.
9. Peak-holding function.
10. Peak automatic discharge function and discharge time can be set freely.
11. It can turn off automatically if it has no operation, and the shutdown time can be set freely.
12. RS-232C output, connecting to computer can realize curve test function; connecting to printer can print 10 groups of stored test data or current test curve.

Work Environment

1. Temperature:0℃-40℃.
2. Relative humidity:35%RH~65%RH.
3. No vibrancy and no cautery around.

- (2) Software environment
Operating system: Windows XP (32bit).
- (3) Specific operation
 - A. Connect force gauge with computer via RS232 cable.
 - B. Turn on the gauge power, make it in working status, then set the serial ports mode as PC state.
 - C. Put CD into computer drive and open software route: CD-ROM/English/Measuring software/ST/ST Test/ST Test.exe.
 - D. Click "New" in the "File" option (See Picture 9).
 - E. There are two modes to choose in new dialog box: Measuring Sequence and Test File (See Picture 10).

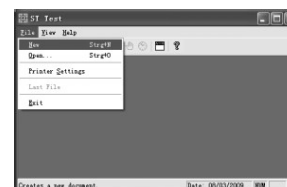

Picture 9

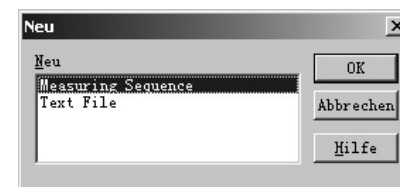

Picture 10

- F. After choosing "Measuring Sequence", please choose corresponding model and serial port, and set the time of capturing the signal of force value in Send Device Command. 1/10 means 0.1 second (See Picture 11: When Hr is 0, Min is 0, Sec is 0, 1/10 is 1, then the capturing time is 0.1 second).

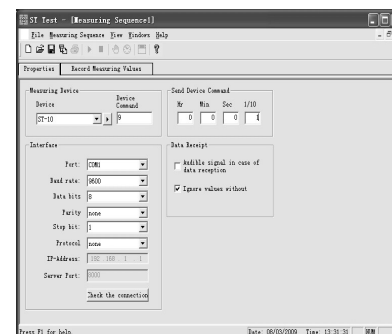

Picture 11

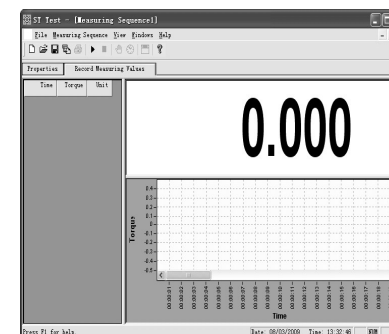

Picture 12

Port Output and Print

This meter is RS-232C level output, which can be connected with printer, computer or other equipments. The matching micro printer must support RS-232C electrical level. The setting method of RS-232 port output is in the Page 7.

Illustration of RS-232 Port

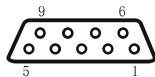

Needle	Signal	Illustration
2	TxD	output signal of SCM
3	RxD	reception signal SCM
5	GND	Signal place

- When RS-232C output is set at Pr.1, it means the single tested Curve will be printed. Press "PRINT", and "Print" will appear on the screen, then test curve will be printed synchronously in the process of testing. The picture on left is a sample.

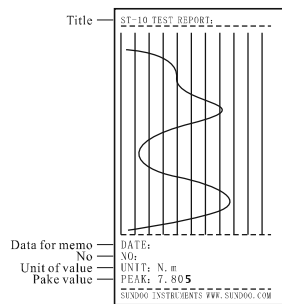

Picture 7

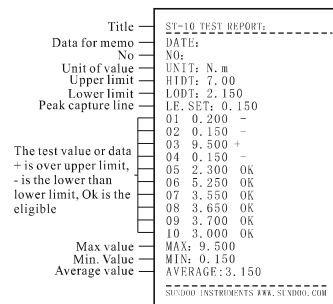

Picture 8

- When RS-232C output is set at Pr.2, the screen will flicker and show "Print". When "PRINT" is pressed and ten groups of data and analysis report will be printed synchronously. Please refer to the picture on right on Page 9.
- When serial port output mode is PC, you can view force curve by software or input 10 groups of stored data to computer by connecting to computer. The required configuration and specific operation are as follow :

(1) Hardware environment

- CPU: Celeron 1G or above.
- Memory: 256MB or above.
- Hard disk available capacity: 300MB or above.
- Drive: CD-ROM or DVD-ROM.

Parts and Functions

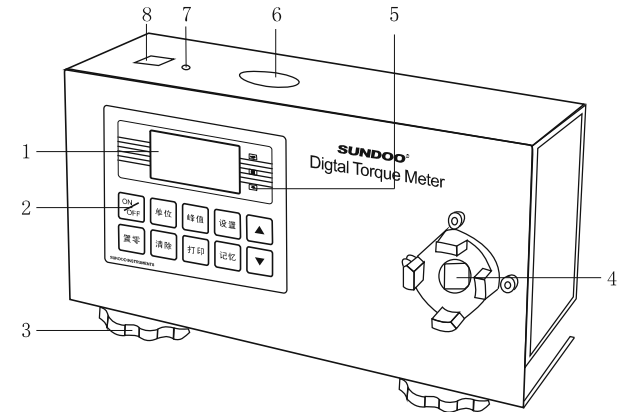

Picture 1

- LCD
- Function button
- Fixture Knobs
- Measuring head
- Pilot lamp
- RS-232C Series port
- Reset hole
- Power connector

1. LCD

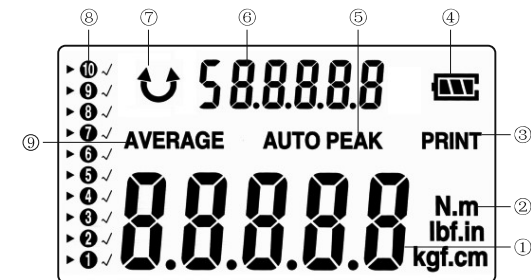

Picture 2

- Torque test value reading, under setting status, it displays set value.
- Torque unit: three different units of measurement (N.m, lbf.in, kgf.cm) can realize automatic conversion.
- Printing indication, print all stored data or single test curve.
- Electric quantity indication of battery.

When the power is low, it displays "☐" or flickers, meaning that the battery needs to be charged.

When the battery is being charged, the power indication "▲" flickers.

⑤ Peak value indication

When it displays "PEAK" on LCD screen, it is max test value in locked status ; when it displays "AUTO PEAK" , the peak is in automatic discharge status.

⑥ Stored test value, average of the stored data or the symbols of indication function at the set state.

⑦ The symbol of torque direction

"↻" is clockwise, "↺" is counterclockwise.

⑧ Store test value

"1 2 3 4 5 6 7 8 9 10" ten locations, each location can store one test value;

"▶" shows that it is current stored reading location;

"√" shows that the location has already stored test value.

⑨ Average indication symbol of stored test data.

2. Function Buttons

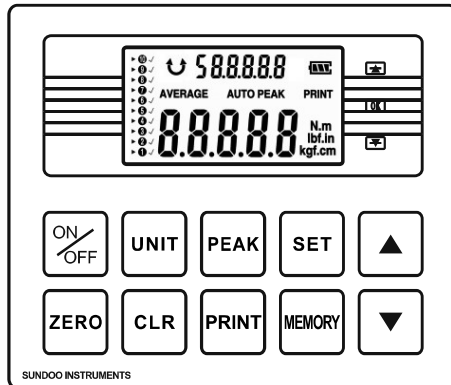

Picture 3



Power ON / OFF



Zero Button

Be used for cleaning to zero, cleaning peak value and saving set value.

1. Install the buffer very rightly on the torque test head while operating.
2. The vertical load of the torque test head should not exceed 1kg.
3. The torque test head should avoid collision to prevent any damage. The torque test head plane size is the following (picture 5).

Buffer's Test Range, Installment and Inspection

1. Buffer's test range

Model	Accessories
ST-1	
ST-2	
ST-5	
ST-10	
ST-20	

2. Buffer's installment

- ①. In compliance with the test need, choose the suitable connecting axis and spring to equip the buffer's assembly(Picture 6).
- ②. If there is not suitable connecting shaft, use M4 screwed hole on $\varnothing 6.3$. Spin the screw with nut into thread hole, and tighten nut . Please use the + head on the screw.

3. Buffer's inspection

- ①. Please check the buffer before operation. The accuracy will be affected if there is dust, oil lack and bending of connecting axis.
- ②. Check the bearing of the buffer regularly. Long-time repetitive using leads to the attrition of the bearing, making the buffer not rotate smoothly and influencing the torque test value.
- ③. If the assembly is loose completely, please twist the screw of the middle into more than 2mm in your hands to avoid the screw be damaged in the process of testing.



Picture 6

- If you want to test torque of other rotational tool or items expect screwdriver, please choose other proper connectors(see test head installation size on page 8).
- If you want to print test curve or stored torque value, connecting with micro printer via instrument communication interface can realize the printing of stored data.
- After using the torque meter, firstly remove the buffer and connector, then turn off the meter, and put back to instrument box.

Test Process of Screwdriver Torque

- First fix the buffer on the torque test head and then install the screwdriver on the buffer.
- Press the PEAK button and choose peak-hold mode.
- Press ZERO button and the torque value on the LCD will be zero.
- Write the screwdriver, and stop writing it when you hear three times sound from screwdriver (Please keep screwdriver and sensor in a line during testing, see picture 4), don't use screwdriver with wrong direction like picture 4 or above 1kg pressure, then record the test value on LCD.
- Repeat the third/fourth procedures continuously for five times, and you will get five times data. Abandon max and min, and obtain the average, which is the torque value from this screwdriver.

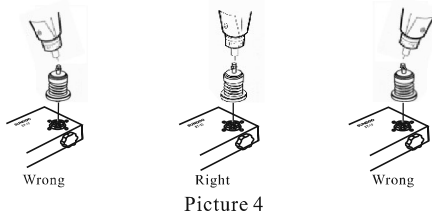

Picture 4

Torque Measuring Head and Connection Dimension

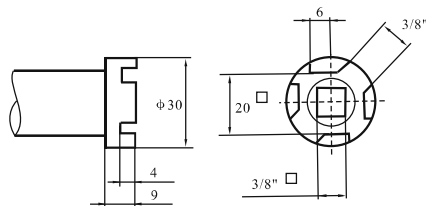

Picture 5

- UNIT** Unit Button
 → →
- CLEAR** Clear Button
 In the state of testing, pressing "CLEAR" will delete the data which "▶" points at; pressing "CLEAR" all the time will delete all the memory testing data.
- PEAK** Peak Button
 Converting three states: peak-holding, peak-holding automatic discharge and real-time tracking of torque value. Real-time tracking of torque value is default status after power on.
- PRINT** Print Button
 Be used for printing current data (See details on Page 9).
- MEMORY** Memory
 Be used for saving test value and calculating the average of stored data; Pressing "MEMORY" can store test value on the LCD screen; Pressing the button all the time and the LCD will display "AVERAGE", thus you could view the average of all stored value.
- SET** Set Button

 - Setting upper and lower limit automatic alarm values.
 - Setting peak-holding automatic discharge time (free setting from 1~30 seconds).
 - Setting automatic shutdown time (free setting from 1~60minutes, 0 is not automatic shutdown).
 - Setting serial port output mode.
 - Setting ON/OFF status of blue background light.
- ▲** Add Button
 A. Under storing test value status, press "▲", and "▶" symbol will forward location. Pressing the "MEMORY" can store test value on the LCD screen. If there is "√" symbol beside the location, it means that test value has been stored into the location, and the new test value will replace

previous stored value.

B. Under setting status, press "▲" and the set value will increase. If you press it all the time, the data will increase continuously.



Reduce Button

A. Under storing test value status, press "▼", and "▶" symbol will backward one location. Pressing the "ESC" can store test value on the LCD screen. If there is "√" symbol beside the location, it means that test value has been stored into the location, and the new test value will replace previous stored value.

B. Under setting status, press "▼" and the set value will decrease. If you press it all the time, the data will decrease continuously.

3. Fixture knobs

It is used to fix the meter on the test stand.

4. Torque test heads

They can be combined with clamps to transmit the torque load to the sensor.

5. The Pilot lamp of upper and lower limit automatic alarm

☀ Pilot lamp of upper limited alarm

OK Normal value indicator lamp

☾ Pilot lamp of lower limited alarm (Power ON indicator light)

Under test status, if test value is in the range of upper and lower limit deviation, normal value indicator lamp "OK" will light, meaning that it is eligible; If test value exceeds upper limit value, the indicator lamp of upper limit "☀" will light, and the buzzer alarms, meaning that it is not eligible; If the test value is less than lower limit value, the indicator lamp of lower limit "☾" will light, and the buzzer alarms, meaning that it is also not eligible. This can inform users that the test result isn't in the range.

6. Communication interface

RS-232C port output is used for connecting printer, PC or other equipments.

7. Reset hole

Be used for restart the instrument when it is disturbed strongly.

8. Power adapter socket

Applied with power adapter DC 12V, 300mA.

Operation Process

1. Turn on the instrument and check the power supply. If it shows "☐" on LCD screen, it means lack of electricity, and the battery group needs to

be charged. The method is as follow: Please put the matched power adapter into the charging port, and plug into AC 220V/50HZ. If "■■■■" flickers, it means that it is being charged. The instrument can automatically calculate the charging time, and it can stop charging when it is full. It can be charged no matter power on or off, and it can be used to test even though it is being charged.

2. Please use fixture knobs to fix torque meter.

3. Normally, the value is zero when the meter is on. If the value is not zero, please press zero button to clear.

4. Press unit button to choose the unit as you required.

5. Setting upper and lower limit deviation values, automatic power-off time, peak-holding automatic discharge time, serial port output mode and background light ON/OFF choice:

Press "SET" for the first time, the LCD screen will display "HIDT", and the digital box displays current upper limit value. Pressing "▲▼" can change current value.

Press "SET" for the second time, the LCD screen will display "LODT", and the digital box displays current lower limit value. Pressing "▲▼" can change current value.

Press "SET" for the third time, the LCD screen will display "P.OFF", and the digital box displays automatic power-off time. Pressing "▲▼" can change current value.

Press "SET" for the fourth time, the LCD screen will display "A.PE", and the digital box displays peak holding automatic-discharge time. Pressing "▲▼" can change current value.

Press "SET" for the fifth time, the LCD screen will display "RS232", and the digital box displays PC, Pr.1 or Pr.2. Pressing "▲▼" can change current status.

Press "SET" for the sixth time, the LCD screen will display "LIGHT", and the digital box displays "ON" or "OFF". "ON" means background lamp is lighting, "OFF" means background lamp isn't lighting. Pressing "▲▼" can change current status.

Pressing "▲▼" for the seventh time, the instrument will save all changed settings and back to working condition.

Note: During setting, pressing "ZERO" can save setting and back to test condition.

6. According to test requirements, please choose proper buffer and fix it on torque test head.