

## WOOD POWDER MOISTURE METER

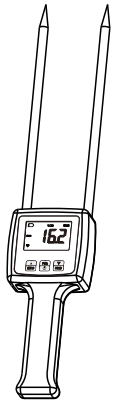

TK100W

All right reserved 2011

Wood powder moisture meter TK100W used for measuring moisture content of wood materials (such as sawdust, paillasse, bamboo powder). It is applicable for paper making, flakeboard, furniture and mechanism of charcoal industry.

### 2. Specification

Display: 4 digital LCD

Measuring range: 0-80%

Temperature: 0-60°C

Humidity: 5%-90%RH

Resolution: 0.1

Accuracy:  $\pm 0.5\%$ n

Operation:

Electrical Resistance Method, Automatic temperature Compensation

Power supply:

4x1.5 AAA size (UM-4) battery

Dimensions:

460×75×35mm

18.3x3x1.4 inch

Weight:

203g (not including batteries)

Guarantee: 1 year

Thanks for choosing our moisture meters!

For your easy to master this instrument as soon as possible, please read following instructions carefully and always keep this meter within easy reach.

### 1. Features:

- 1.1. It is portable, compact, easy to use and the moisture measurement readings are instant.
- 1.2. Digital display with back light gives exact and clearly reading although you stay at the somber conditions.
- 1.3. It will save time and expense by monitoring dryness and helps to prevent deterioration & decay caused by moisture whilst in storage, therefore processing will be more convenient and efficient.
- 1.4. The moisture meter operates by electrical

resistance and has automatic temperature compensation.

- 1.5. Measurements are taken by inserting the sensors into the bale of wood powder related materials.
- 1.6. Manual off at any time. Auto power off after 5 minutes from last operation.

### 3. Panel descriptions

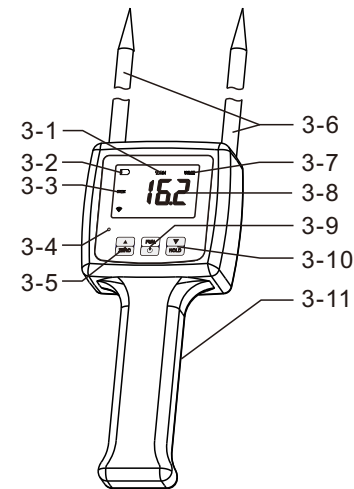

- |                   |                     |
|-------------------|---------------------|
| 3-1 RH% symbol    | 3-5 zero/inc key    |
| 3-2 low battery   | 3-6 pin probe       |
| 3-3 max symbol    | 3-7 material symbol |
| 3-4 warning light | 3-8 testing value   |

- |                        |                    |
|------------------------|--------------------|
| 3-9 power/function key | 3-10 hold/dec key  |
|                        | 3-11 battery cover |

### 4. Operation procedure

- 4.1 Turn on the power key 3-9, the symbol "0" will be showed on display. It will need zeroing if showed other value, please depress ZERO key 3-5 while the probe sensor without touch anything, or zeroing is not efficient. make zeroing can decrease the effect from the temperature and humidity in the air.
- 4.2 Hold the instrument with your hand, insert the probes

into the materials straightly ,the probes are more deeper ,the value is better.

- 4.3 Depress Hold key 3-10,the symbol “max”will be showed on display, then the max value must be stored on display when measuring. Depress the key 3-10 again, this function will be canceled.

### **5.Warning setting**

- 5.1 Depressing key 3-9 and don't release until “AL2” showed on display(it will takes 5 seconds to complete operation),then

press key 3-5 or 3-10 to choose your suitable value according to your needs, press key 3-10 again back to the operation state.

- 5.2 Setting the “AL1” just the same ways as “AL2”.
- 5.3 Usually ,“AL2”must larger than “AL1”,if the “AL2” less than “AL1” during setting process , then the instrument will be returned back the factory setting, just to say,AL1=13,AL2=18.

### **6.Replace batteries**

When battery symbol showed on display, it must replace the batteries in time. Slide the

batteries cover ,put the batteries into the hole correctly.

### **Notes:**

Please take out the batteries if the instruments without use for a long time.

Put the probe in the air without touch anything when zeroing, or the zeroing is not efficient.