

# Webster Hardness Tester

## 1. Instrument Structure

The structure of Webster hardness testers is shown as Fig. 1:

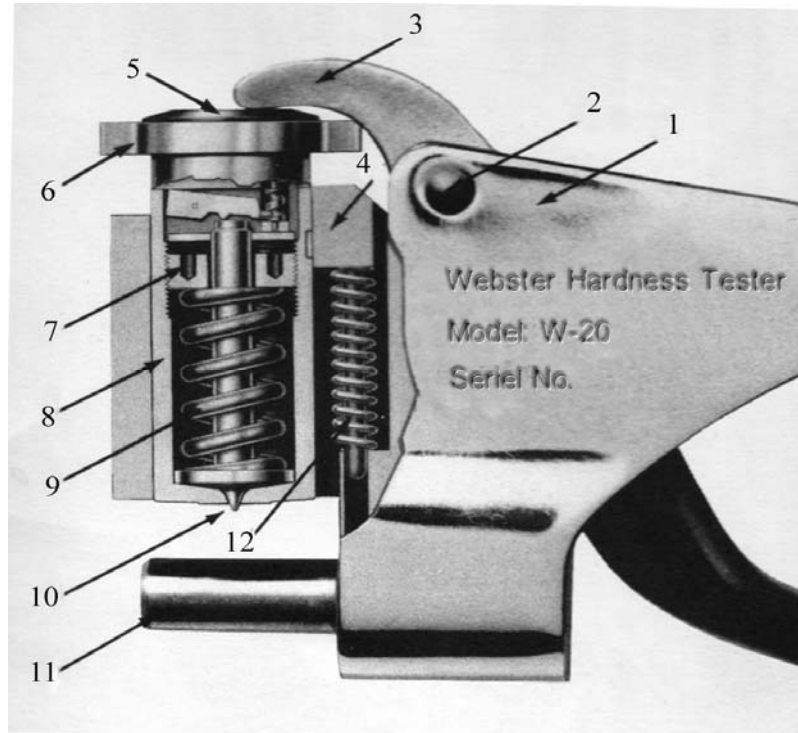

- |                     |                       |
|---------------------|-----------------------|
| 1 – Frame           | 2 – Pivot screw       |
| 3 – Handle          | 4 – Reset key         |
| 5 – Adjusting screw | 6 – Dial head         |
| 7 – Adjusting nut   | 8 – Indenter cylinder |
| 9 – Load spring     | 10 – Indenter         |
| 11 – Anvil          | 12 – Return spring    |

Fig. 1 Structure of the Instrument

The indenters of each type of Webster hardness testers are different. The shapes of three types of indenters are shown as Fig.2.

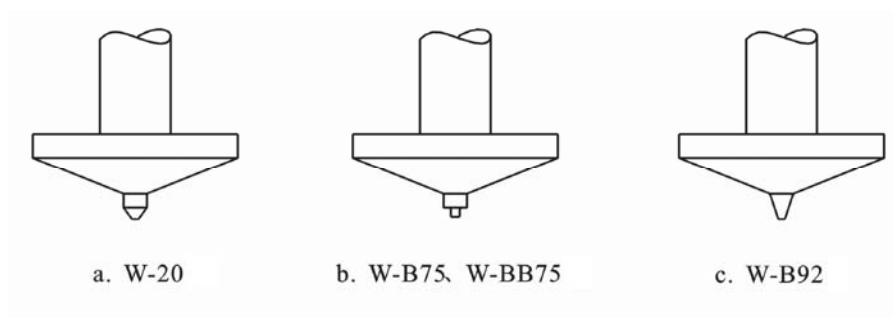

Fig. 2 Indenter Shapes

## 2. Main Technical Parameters

Festing Range: 0~20HW  
Accuracy: 0.5HW  
Eqnivaient range: See Table 1  
Weight: 0.5kg

**Table 1: Models Selection**

Item	Type	Applicable Materials	Hardness Range	Specimen Size/mm
1	W-20	Aluminum alloy	25-110 HRE 58-131 HV	Thickness 0.4-6 Inner diameter>10
2	W-20a			Thickness 0.4-13 Inner diameter>10
3	W-20b			Thickness 0.4-8 Inner diameter>6
4	W-B75	Brass in hard or half hard state, super-hard aluminum alloy	63-105 HRF	Thickness 0.4-6 Inner diameter>10
5	W-B75b			Thickness 0.4-8 Inner diameter>6
6	W-BB75	Soft brass, pure copper	18-100 HRE	Thickness 0.4-6 Inner diameter>10
7	W-BB75b			Thickness 0.4-8 Inner diameter>6
8	W-B92	Cold-rolled steel sheet, stainless steel	50-92 HRB	Thickness 0.4-6 Inner diameter>10

## 3. Operating Method

Put the specimen between the anvil and the indenter and press down the handle until the bottom is felt. At the time the dial indicator will point at a reading which is the hardness value obtained. Excessive pressure beyond this limit will not damage the tester, but it is unnecessary. Hold tight the handle when reading the value. Any torsion or movement will make the reading incorrect during the test.

## 4. Verification and Calibration

### 4.1 Verification of the Instrument

#### 4.1.1 Full Scale Verification

Hold tight the handle directly to the bottom without putting the specimen in the opening of the hardness tester. The indicator should point at  $20 \pm 0.5HW$ . If the test reading does not meet the requirement, calibration of the full scale should be carried out according to Step 4.2.1.

#### 4.1.2 Test Block Verification

The standardized hardness block is tested by the hardness tester. For B, B-1 and B-2 Webster hardness testers, the dial indicator should point at the specified hardness values with tolerance of  $\pm 0.5HW$ ; for B75, B75b and B92, the indicator should point at  $5HW \pm 0.5HW$ ; and for BB75 and BB75b, the indicator should point at  $17HW \pm 0.5HW$ . If the test reading does not meet the requirement, calibration of the load spring should be made according to Step 4.2.2.

Operators should regularly check the accuracy of the instrument by the standard hardness block. Calibration should be made if any deviation occurs. When testing the hardness block, use only its upper surface.

### 4.2 Calibration of the Instrument

Calibration of this instrument includes calibration of the Full Scale and calibration of the load

spring. Calibration of the Full Scale is actually to set a benchmark for the scale 20. Calibration of the load spring is actually to provide with a reference point for the instrument, and this reference point is the known hardness value of the standard hardness block. After calibrating, the full scale should be verified again and its reading should conform to 4.1.1.

#### 4.2.1 Calibration of Full Scale

Hold tight the handle directly to the bottom without putting the specimen in the opening of the hardness tester. As shown in Fig. 3, regulate the full-scale adjusting screw with a small screwdriver to bring the indicator at Scale 20. If the pointer pointing at a smaller value than 20, the adjusting screw should be regulated clockwise; if the indicated value is greater than 20, the adjusting screw should be regulated anticlockwise. If the pointer can not be set to the full scale 20 by regulating the adjusting screw, replace the indenter according to the steps in Section 5.



Fig.3 Regulate the adjusting screw



Fig.4 Regulate the adjusting nut

#### 4.2.2 Calibration of the Load Spring

Screw off the pivot screw, and take out the lower handle from the main frame, then remove the dial head from the indenter cylinder, while leaving the cylinder in the frame. Then the adjusting screw with grooves can be seen in the indenter cylinder. As shown in Fig. 4, rotate the adjusting screw with the special wrench equipped with the instrument. If the reading of the hardness block is smaller, rotate the adjusting nut anticlockwise; otherwise, rotate the adjusting nut clockwise. When the nut is rotated 1/4 circle, the scale reading will change 2-3 units. Reassemble the tester and verify the hardness block after regulating it.

Repeat the above steps until the full scale and the reading of the hardness block are both according with the requirements in Section 4.1.

DO NOT rotate the adjusting screw at will except normal calibration. DO NOT calibrate the readings of the testing standard hardness blocks by regulating the adjusting screw.

#### 4.2.3 Calibration of the B-1 Webster Hardness Tester

Put the calibrating sheath on the anvil first; then calibrate the instrument according to the calibrating procedure in 4.2.

### 5. Replace the Indenter

In case the pointer can not be set to the full scale 20 by regulating the adjusting screw, which means the indenter is worn, the indenter should be changed.

Shown below is how to replace the indenter:

Screw off the pivot screw, and take out the lower handle from the main frame, then remove

the dial head from the indenter cylinder, but the cylinder still stays in the frame. Then the adjusting screw with grooves can be seen in the indenter cylinder. As shown in Fig. 4, rotate the adjusting screw with the calibration wrench equipped with the instrument, then take out the indenter and replace with a new one. Calibrate the instrument again according to the calibrating procedure in 4.2.

After the indenter is replaced, adjust the pressure of the load spring with the adjusting nut, when the resistance of the load spring is sensed, only one tight rotating of the nut is enough. The indenter tip could be damaged by the over pressure of the load spring at first adjustment.

## 6. Verification Report

The verification report should include the following information:

- Material brand and name
- Type and serial number of the hardness tester
- Reading of each test (accurate to 0.5 scale)
- Average hardness value (accurate to 0.5 scale)
- No. of standard applied
- Inspector and date

## 7. Standard Package

- 1 Tester
- 1 standard hardness block (attached with measurement and inspection report)
- 1 spare indenter
- 1 wrench
- 1 small screwdriver
- 1 instruction manual
- 1 carrying case

## 8. Optional Accessories

- spare indenter
- standard hardness block
- spare dial glass

## 9. Maintenance

The testers of this series are precision instruments, of which the service life mainly depends on the correct method of use and timely and proper maintenance. The following items should be taken into account:

**9.1 Prevent contamination.** This instrument should often be cleaned with the soft cloth to remove the dust and dirt on the surface of it, especially on the anvil and supporting surface of the cylinder. Specially prevent the dirty things to get in from the dial seams or indenters, otherwise, the filthy things from those parts might influence on the testing precision or cause malfunction.

**9.2 Prevent rust.** Although all the parts of instrument have been treated to prevent rust, the improper maintenance or long time of use on the production spot without paying attention to maintenance may also cause the rust to some components. When using it, pay special attention to its waterproof performance except clean it frequently, because many parts will bear rust with water, the water in the dial may cause deadly rust to make the instrument useless.

**9.3 Prevent falling off.** This instrument is made up of many precision components, falling off of it will result in the permanent damage to some parts.

**9.4 Disassembly forbidden.** The testing accuracy of this instrument is guaranteed by the good collaboration of some of the precision parts. This collaboration is not easy for the nonprofessional people to master. Consequently, disassembly of the parts is not allowed except for those allowed in calibration, otherwise this will bring you trouble and the warranty of this instrument will terminate.

## **10. Factors Affecting the Test Accuracy**

**10.1 Test Piece.** The surface of the specimen should be treated smooth and clean. The dirt on the specimen, especially the tiny sand grains may affect the test accuracy.

**10.2 Sensitivity.** The instrument scale below 4HW and above 17HW, its sensitivity will decline strikingly, and the testing accuracy will also be reduced. Applying another tester should be considered.

**10.3 Edge of test piece.** The distance between the testing point and the edge of the test piece should be bigger than 5mm. Test close to the edge of the test piece will affect the accuracy.

**10.4 Adjacent indentations.** During the test the distance between the two adjacent indentations should be no smaller than 6mm; otherwise, the previous indentation will affect the next testing accuracy.

**10.5 Oxide film.** Although the hard oxide film is thin, it will also influence on the hardness accuracy of the aluminum extrusions. Experiences indicate that the oxide film with hardness of 10 $\mu$ m will increase the hardness value by 0.5~1HW.

**10.6 Coatings.** All kinds of coatings will affect severely the testing accuracy, so sand paper or solvent is needed to remove the coatings first before carrying on the hardness testing.

**10.7 Operation.** Improper operation will affect the accuracy of the hardness.

10.7.1 The accuracy of this instrument should be often checked in use to see if the full scale point (20HW) and the calibration point are still correct. Calibrate it immediately when something is wrong.

10.7.2 The surface of the test piece should be vertical to the indenter and the bottom of specimen should contact the anvil during the test, otherwise errors will occur.

10.7.3 During the test enough grip strength should be applied at one time, adding the strength slowly will make the test result inclined to the low side.

10.7.4 During the test the test piece should not twist, otherwise it will make errors and damage the indenter.

Table 2 Hardness Conversion Table for W-20 Series Hardness Testers

<b>Webster HW</b>	<b>Rockwell E HRE</b>	<b>Rockwell F HRF</b>	<b>Vickers HV</b>
18	101	98.5	131
17	97	95	119
16	92.5	91	108
15	88	87.2	99
14	84	83	91
13	79.5	78	83
12	75	74	78
11	71	70	73
10	67	66	69
9	62.5	62.5	65
8	58	58	61
7	54	54	58
6	49.5	50	
5	45	46.5	
4	41		

Table 3 Hardness Conversion Table for W-B75 series Hardness Testers

HW	HRB
4	53.0
5	53.3
6	54.1
7	54.8
8	56.7
9	58.5
10	60.8
11	63.4
12	66.4
13	69.7
14	73.5
15	77.9
16	82.1
17	86.9
18	92.2

Table 4 Hardness Conversion Table for W-Bb75 Series Hardness Testers

HW	HRF
4	30.2
5	34.9
6	39.6
7	44.3
8	49.0
9	53.7
10	58.4
11	63.1
12	67.8
13	72.5
14	77.3
15	82.0
16	86.7
17	91.4
18	96.1

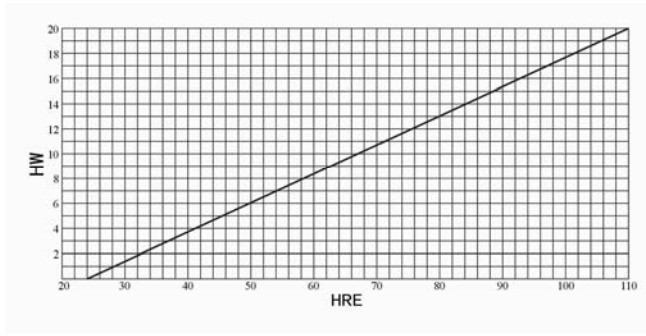

Fig. 5 W-20 Series Hardness Conversion Curve

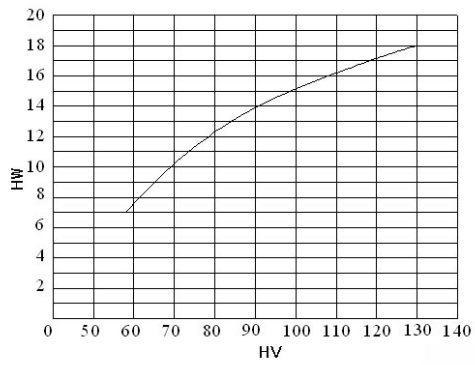

Fig. 6 W-20 Series Hardness Conversion Curve

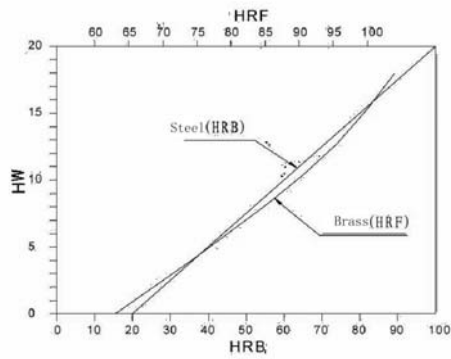

Fig. 7 W-B75 Series Hardness Conversion Curve

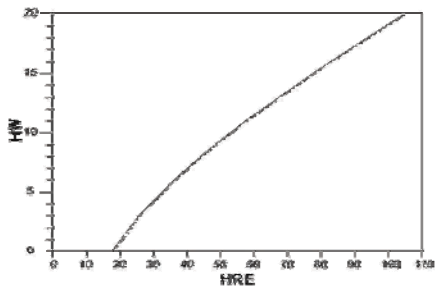

Fig. 8 W-BB75 Series Hardness Conversion Curve

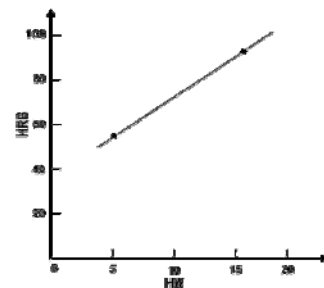

Fig. 9 W-B92 Series Hardness Conversion Curve