

# General Warranty

We warrant that the product will be free from defects in materials and workmanship for a period of 3 years (1 year for accessories) from the date of purchase of the product by the original purchaser from our company. This warranty only applies to the original purchaser and is not transferable to a third party.

If the product proves defective during the warranty period, we will either repair the defective product without charge for parts and labour, or will provide a replacement in exchange for the defective product. Parts, modules, and replacement products used by our company for warranty work may be new or reconditioned like new. All replaced parts, modules and products become the property of our company.

In order to obtain service under this warranty, the customer must notify our company of the defect before the expiration of the warranty period. Customer shall be responsible for packaging and shipping the defective product to the designated service centre, a copy of the customers proof of purchase is also required.

This warranty shall not apply to any defect, failure or damage caused by improper use or improper or inadequate maintenance and care. We shall not be obligated to furnish service under this warranty a) to repair damage resulting from attempts by personnel other than our company representatives to install, repair or service the product; b) to repair damage resulting from improper use or connection to incompatible equipment; c) to repair any damage or malfunction caused by the use of not our supplies; or d) to service a product that has been modified or integrated with other products when the effect of such modification or integration increases the time or difficulty of servicing the product.

Please contact the nearest Sales and Service Offices for services.

**Excepting the after-sales services provided in this summary or the applicable warranty statements, we will not offer any guarantee for maintenance declared or hinted, including but not limited to the implied guarantee for marketability and special-purpose acceptability. We should not take any responsibilities for any indirect, special, or consequent damages.**

# Table of Contents

<b>1.Safety Information.....</b>	<b>1</b>
<b>Safety Terms and Symbols.....</b>	<b>1</b>
<b>General Safety Requirements.....</b>	<b>2</b>
<b>Measurement Limits.....</b>	<b>3</b>
Main Input Terminals Measurement Limits.....	3
Current Input Terminal Measurement Limits.....	3
<b>Measurement Category.....</b>	<b>3</b>
<b>2.Quick Start.....</b>	<b>5</b>
<b>General Inspection.....</b>	<b>5</b>
<b>Dimensions.....</b>	<b>5</b>
<b>Foot Stool Adjustment.....</b>	<b>6</b>
<b>Front Panel Overview.....</b>	<b>6</b>
<b>Rear Panel Overview.....</b>	<b>8</b>
<b>User Interface.....</b>	<b>9</b>
<b>Power On.....</b>	<b>9</b>
<b>Measurement Connections.....</b>	<b>11</b>
<b>Data Record Function.....</b>	<b>13</b>
Manual Record.....	13
Auto Record.....	13
<b>3.Troubleshooting.....</b>	<b>15</b>
<b>4.Appendix.....</b>	<b>16</b>
<b>Appendix A: Enclosure.....</b>	<b>16</b>
<b>Appendix B: General Care and Cleaning.....</b>	<b>16</b>
<b>Appendix C: Line Fuse Replacement (Only for AC power supply model).....</b>	<b>17</b>
<b>Appendix D: Charging and Replacement of Battery (Only for DC power supply model).....</b>	<b>17</b>

# 1. Safety Information

## Safety Terms and Symbols

### Safety Terms

**Terms in this Manual.** The following terms may appear in this manual:



**Warning:** Warning indicates the conditions or practices that could result in injury or loss of life.



**Caution:** Caution indicates the conditions or practices that could result in damage to this product or other property.

**Terms on the Product.** The following terms may appear on this product:

**Danger:** It indicates an injury or hazard may immediately happen.

**Warning:** It indicates an injury or hazard may be accessible potentially.

**Caution:** It indicates a potential damage to the instrument or other property might occur.

### Safety Symbols

**Symbols on the Product.** The following symbol may appear on the product:

	Direct current (DC)		Warning, risk of electric shock
	Alternating current (AC)		Caution, risk of danger (refer to this manual for specific Warning or Caution information)
	Both direct and alternating current		Conforms to European Union directives
	Ground terminal		Chassis Ground
<b>CAT I (1000V)</b>	IEC Measurement Category I. The maximum measurable voltage is 1000 Vpk in the HI -LO terminal.		
<b>CAT II (600V)</b>	IEC Measurement Category II. Inputs may be connected to AC mains power (up to 600 VAC) under Category II overvoltage conditions.		
	This product complies with the WEEE Directive (2012/19/EC) marking equipment. The affixed product label indicates that you must not discard this electrical/electronic product in domestic household waste.		

## General Safety Requirements

**Before any operations, please read the following safety precautions to avoid any possible bodily injury and prevent this product or any other products connected from damage. In order to avoid any contingent danger, this product is only used within the range specified.**

- **Use Proper Power Cord.** Use only the power cord supplied with the product and certified to use in your country.
- **Product Grounded.** This instrument is grounded through the power cord grounding conductor. To avoid electric shock, the grounding conductor must be grounded. The product must be grounded properly before any connection with its input or output terminal.
- **Limit operation to the specified measurement category, voltage, or amperage ratings.**
- **Check all Terminal Ratings.** To avoid instrument damage and the risk of electric shock, check all the Measurement Limits and markers of this product. Refer to the user's manual for the Measurement Limits before connecting to the instrument. Do not exceed any of the Measurement Limits defined in the following section.
- **Do not operate without covers.** Do not operate the instrument with covers or panels removed.
- **Use Proper Fuse.** Use only the specified type and rating fuse for this instrument.
- **Avoid exposed circuit.** Do not touch exposed junctions and components when the instrument is powered.
- **Do not operate if in any doubt.** If you suspect damage occurs to the instrument, have it inspected by qualified service personnel before further operations.
- **Use your instrument in a well-ventilated area.** Inadequate ventilation may cause increasing of temperature or damages to the device. Please keep well ventilated and inspect the intake regularly.
- **Do not operate in wet conditions.** In order to avoid short circuiting to the interior of the device or electric shock, please do not operate in a humid environment.
- **Do not operate in an explosive atmosphere.**
- **Keep product surfaces clean and dry.**
- **Only the qualified technicians can implement the maintenance.**

## Measurement Limits

The protection circuitry of the multimeter can prevent damage to the instrument and protect against the danger of electric shock, when the Measurement Limits are not exceeded. To ensure safe operation of the instrument, do not exceed the Measurement Limits shown on the front panel, it is defined as follows:

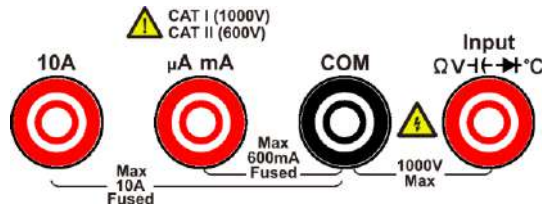

### Main Input Terminals Measurement Limits

The  $\Omega$ V-⚡-°C Input and COM Input terminals are used for voltage, resistance, continuity, frequency (period), capacitance, diode, and temperature test measurements. The Measurement Limit is defined for these terminals:

- **$\Omega$ V-⚡-°C Input to COM Input Measurement Limit**

The measurement limit from  $\Omega$ V-⚡-°C Input to COM Input is 1000 VDC or 750 VAC, which is also the maximum voltage measurement. This limit can also be expressed as 1000 Vpk maximum.

### Current Input Terminal Measurement Limits

- The measurement limit from 10A input terminal to COM Input terminal is 10 A (DC or AC).
- The measurement limit from  $\mu$ A mA input terminal to COM Input terminal is 600 mA (DC or AC).

Note that the current input terminals will always be at approximately the same voltage as the COM Input terminal.

## Measurement Category

The safety rating of the multimeter:

### 1000 V, CAT I

IEC Measurement Category I. The maximum measurable voltage is 1000 Vpk in the HI -LO terminal.

### 600 V, CAT II

IEC Measurement Category II. Inputs may be connected to AC mains power (up to 600 VAC) under Category II overvoltage conditions.

### Measurement category definition

**Measurement CAT I** applies to measurements performed on circuits not directly connected to the AC mains. Examples are measurements on circuits not derived from the AC mains and specially protected (internal) mains- derived circuits.

## 1.Safety Information

---

**Measurement CAT II** applies to protect against transients from energy-consuming equipment supplied from the fixed installation, such as TVs, PCs, portable tools, and other household circuits.

**Measurement CAT III** applies to protect against transients in equipment in fixed equipment installations, such as distribution panels, feeders and short branch circuits, and lighting systems in large buildings.

**Measurement CAT IV** applies to measurements performed at the source of the low-voltage installation. Examples are electricity meters and measurements on primary over current protection devices and ripple control units.

## 2. Quick Start

### General Inspection

After you get a new multimeter, it is recommended that you should make a check on the instrument according to the following steps:

**1. Check whether there is any damage caused by transportation.**

If it is found that the packaging carton or the foamed plastic protection cushion has suffered serious damage, do not throw it away first till the complete device and its accessories succeed in the electrical and mechanical property tests.

**2. Check the Accessories**

The supplied accessories have been already described in the *Appendix A: Enclosure* of this Manual. You can check whether there is any loss of accessories with reference to this description. If it is found that there is any accessory lost or damaged, please get in touch with our distributor responsible for this service or our local offices.

**3. Check the Complete Instrument**

If it is found that there is damage to the appearance of the instrument, or the instrument cannot work normally, or fails in the performance test, please get in touch with our distributor responsible for this business or our local offices. If there is damage to the instrument caused by the transportation, please keep the package. With the transportation department or our distributor responsible for this business informed about it, a repairing or replacement of the instrument will be arranged by us.

### Dimensions

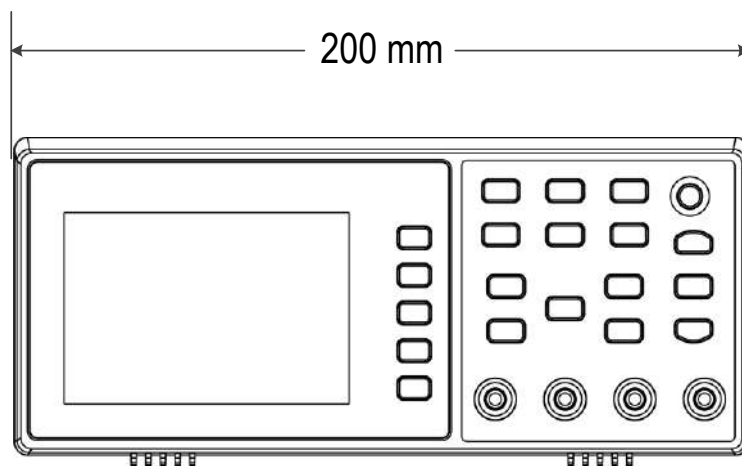

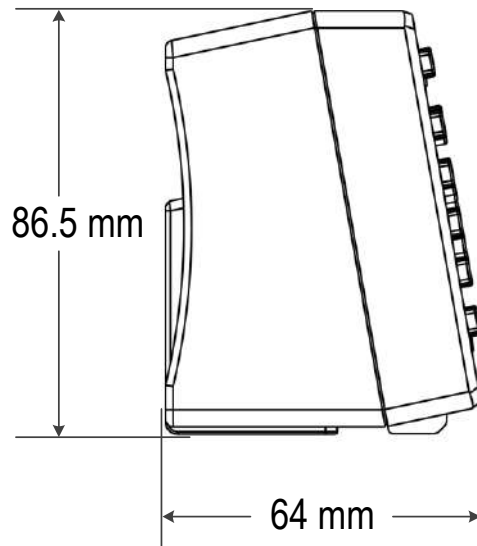

## Foot Stool Adjustment

Unfold the foot stool on the bottom of the multimeter.

## Front Panel Overview

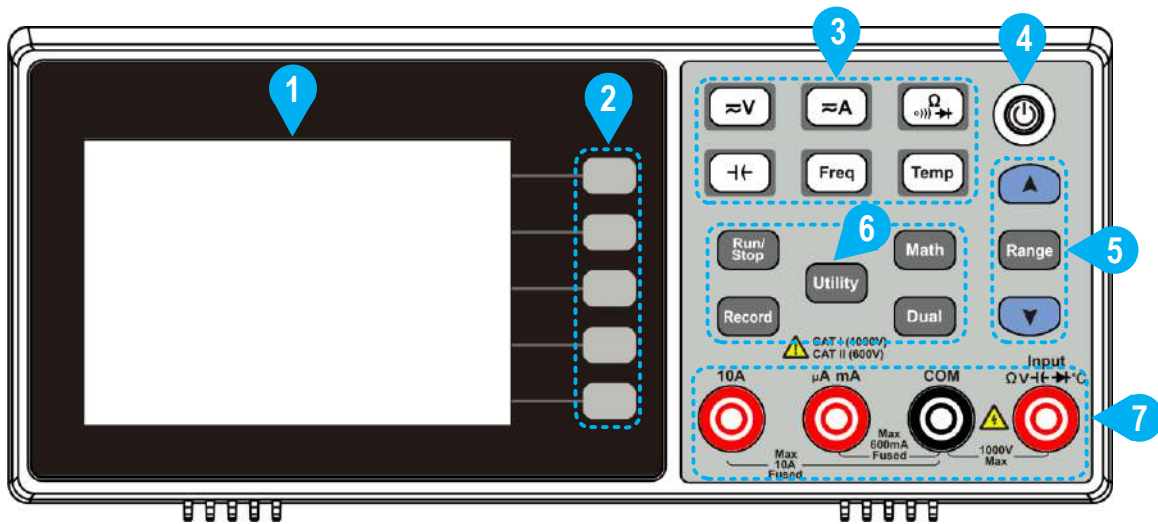











Figure 2-1 Front panel overview

Item	Name	Description
1	LCD	Display the user interface
2	Menu selection Keys	Activate the corresponding menu



## 2.Quick Start

3	<b>Measurement Function Keys</b>	 DC or AC voltage measurements  DC or AC current measurements  Resistance, continuity, and diode measurements  Capacitance measurements  Frequency/Period measurements  Temperature measurements
4	<b>Power button</b>	Turn on/off the multimeter.
5	<b>Range/Direction Keys</b>	<p>When the <b>Range</b> softkey is shown on the right menu, you can press the <b>Range</b> key to switch between auto and manual range. Press  or  keys to enable manual range, and increase or decrease the measurement range. When setting a parameter, press <b>Range</b> to move the cursor, press  or  keys to increase or decrease the value.</p>
6	<b>Operation Keys</b>	
	Run/Stop	Start or stop auto trigger. When the trigger is stopped, the displayed data will be held.
	Record	Access menus of manual record and auto record. See page 13, <i>Data Record Function</i> .
	Utility	Set the auxiliary system function, including Language, Backlight, Clock, Default, and Serial port.
	Math	Perform math operations (Max/Min, dB/dBm) on the measurement results.
	Dual	Press this key to display the function list on the right menu, select a function, if the function is supported, the reading will be displayed in the Vice Display.
7	<b>Input Terminals</b>	Signal input terminals, used for AC/DC current, voltage, resistance, continuity, frequency (period), capacitance, diode, and temperature test measurements.

## Rear Panel Overview

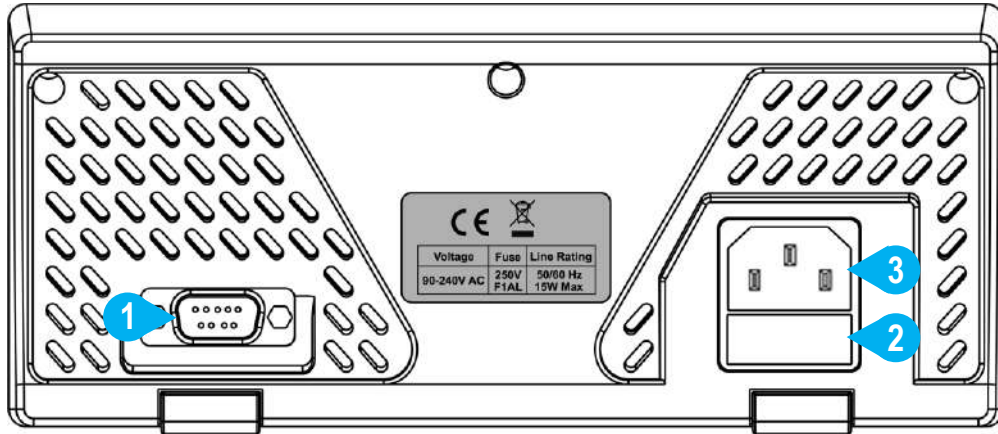

Figure 2-2 Rear panel overview(Take the -R model AC power supply for instance)

Item	Name	Description
1	<b>Communication interface</b>	-R models can be connected to a computer through a serial port; -U model can be connected to the computer via USB Device.
2	<b>Line Fuse</b>	The fuse rating is 250 V, F1AL. To replace the fuse, see page 17, <i>Appendix C: Line Fuse Replacement</i> .
3	<b>AC Mains Input</b>	AC mains input connector.

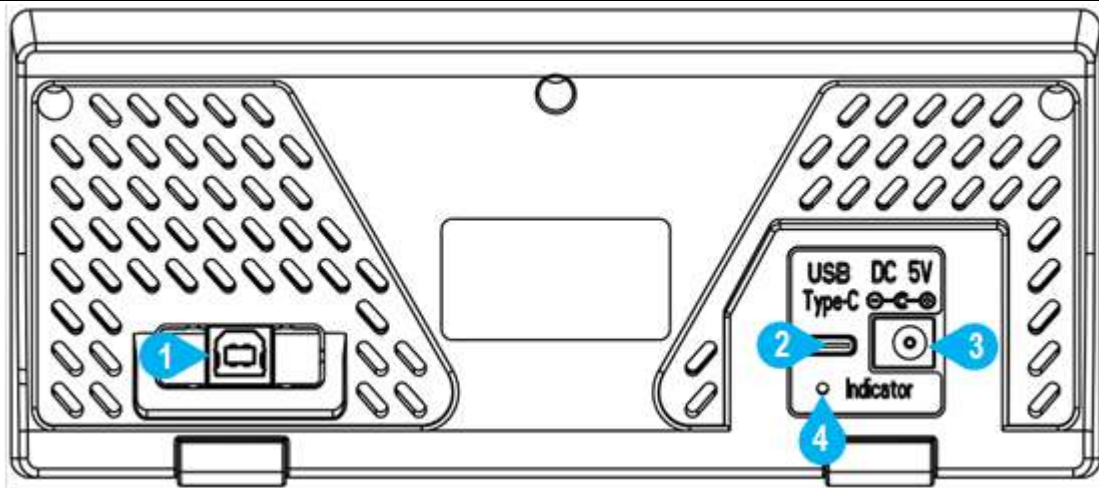
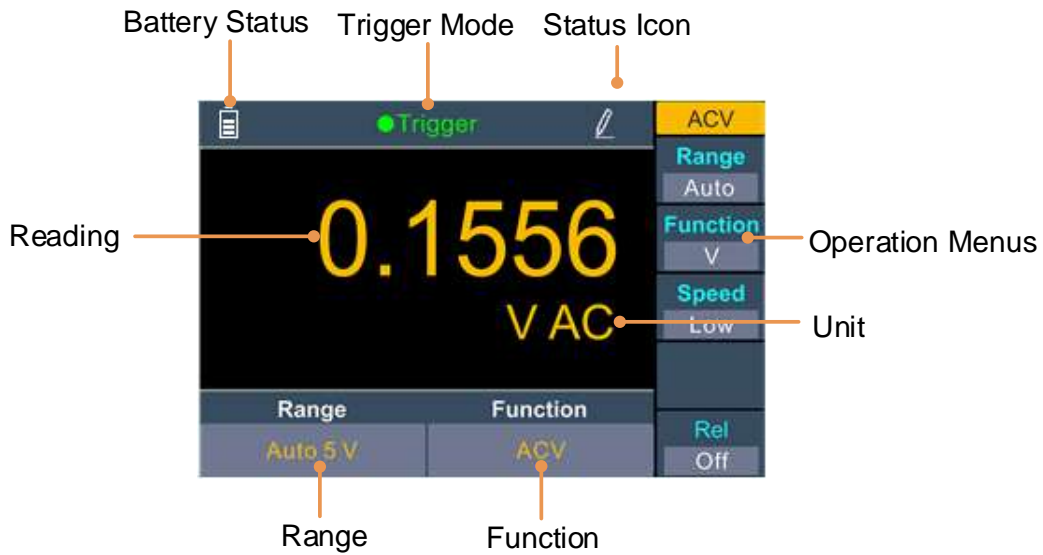

Figure 2-3 Rear panel overview(Take the AC power supply for instance)

1	<b>Communication interface</b>	Connect the PC through this port.
2	<b>USB Type -C port</b>	DC mains input connector.
3	<b>Mains Input</b>	DC mains input connector.
4	<b>Indicator</b>	Fully charged: green light; Charging: red light ; Charging fault: LED blinking.

## User Interface



### Trigger Mode

Display	Description
Trigger	Auto trigger

### Status Icon

Icon	Description
	Auto record function is running
	Manual record

Figure 2-4 User interface (Single display - Take the model with DC power supply for instance)

**Note:** The following screenshots take the model with AC power supply for instance.

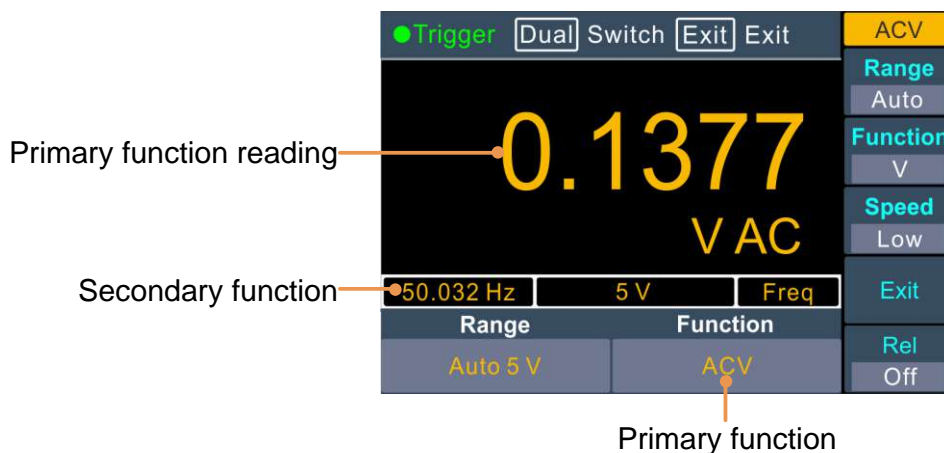

Figure 2-5 User interface (Dual display)

## Power On

(1) Model with AC power supply: Connect the instrument to the AC supply using the supplied power cord.

Model with DC power supply: use the USB to DC cable provided in the accessory to

connect the instrument to the USB adapter, it can also be powered by USB Type-C.



**Warning:**

To avoid electric shock, the instrument must be grounded properly.

When using an adapter for power supply, it is recommended to use a grounded adapter, otherwise it may have a certain impact on the measurement.

- 
- (2)** Press down the **power button** at the front panel, the screen shows the boot screen.

## Measurement Connections

After selecting the desired measurement function, please connect the signal (device) under test to the multimeter according to the method below. To avoid instrument damage, do not discretionarily switch the measurement function when measuring.

### DC Voltage Measurement

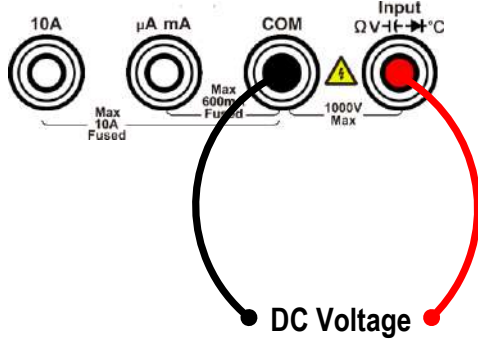

### AC Voltage Measurement

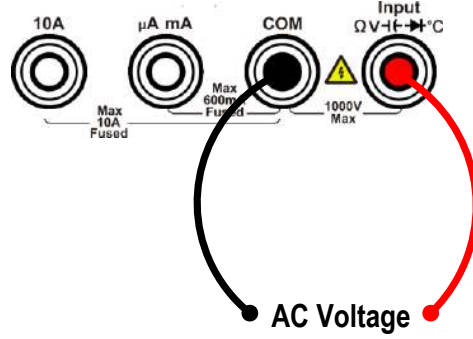

### DC Current Measurement

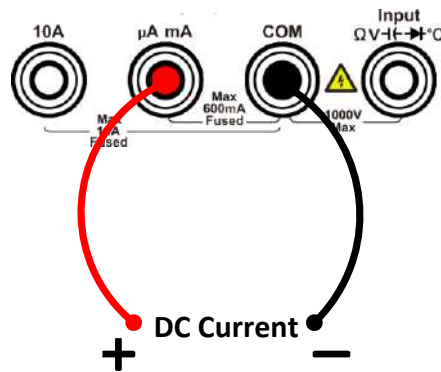
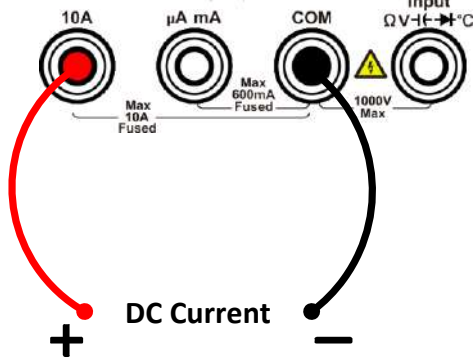

### AC Current Measurement

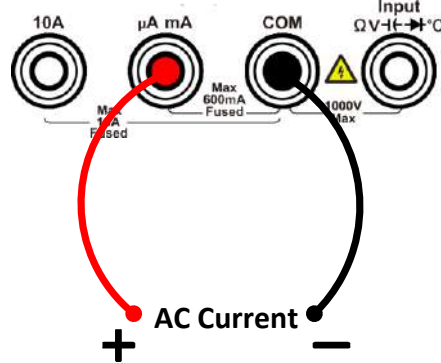
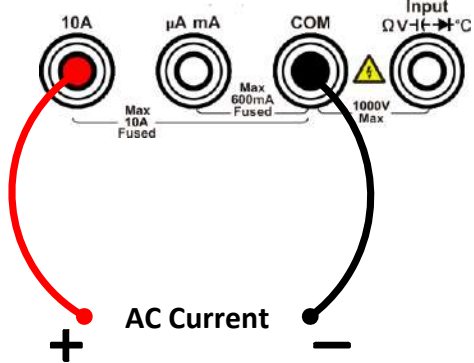

### Resistance Measurement

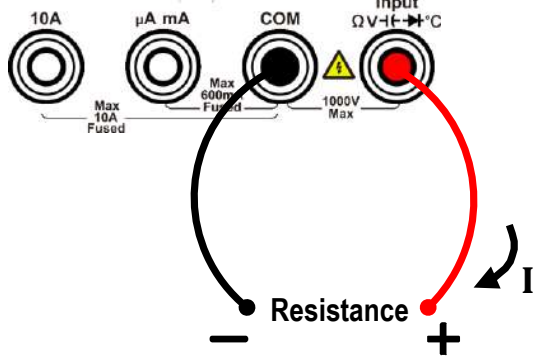

### Continuity Test

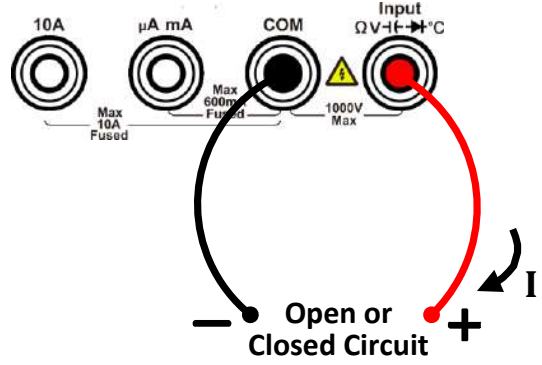

### Diode Measurement

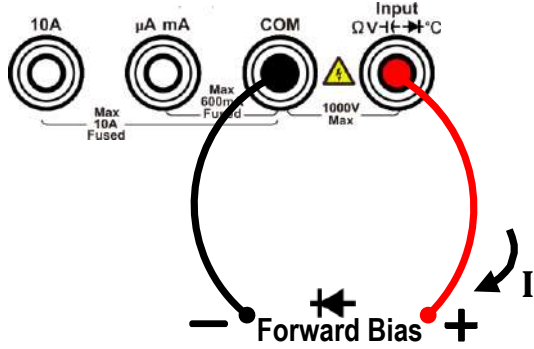

### Capacitance Measurement

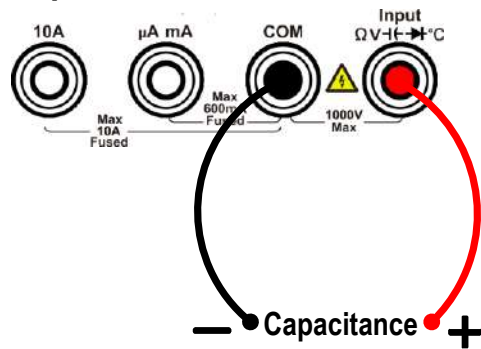

### Frequency/Period Measurement

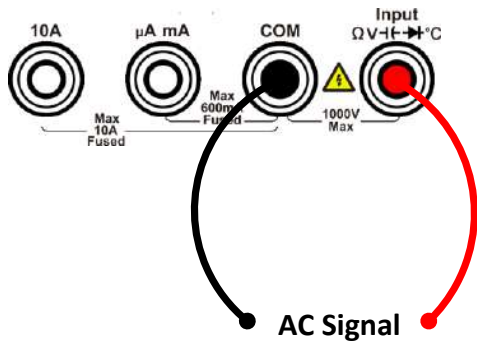

### Temperature Measurement

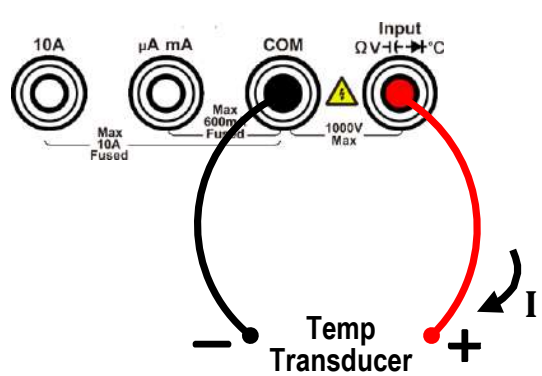

## Data Record Function

Data record function includes manual record and auto record. You can use any or both functions to record the data. Manual and automatic records share a table of data stored in internal storage. The maximum number of recorded points is 1000. After collecting the data, it can be exported to the computer.



**Manual record:** Press the **Record** key -> **Manual** -> **Save** softkey to save current reading to the DB data.

**Auto record:** Press the **Record** key -> **Auto** softkey, after setting number of readings, sample interval, press the **Start** softkey to the DB data.

### Manual Record

- Collect data:** Press the front panel **Record** key, press the **Manual** softkey. Press the **Save** softkey once to save the current reading to the data table by serial number. The  icon will show up on the top of the display.

**Note:** The measurement function can be switched during manual record. Save only the main display readings.

- View the manual record:** Press the front panel **Record** key, press the **Manual** softkey to display the data table. Press  or  keys to turn the page.

**Note:**

- When the recording data exceeds the current range, the data will be marked as "overload".
- When the relative value operation is enabled, the recorded data is still the reading when the relative value is closed.

●Trigger			Manual
NO	MODE	VALUE	Save
1	DCV	-00.362mVDC	Clear
2	DCV	-00.362mVDC	
3	DCV	-00.362mVDC	
4	DCV	-00.362mVDC	
5	DCV	-00.362mVDC	
6	DCV	-00.362mVDC	
7	DCV	-00.362mVDC	
8	DCV	-00.362mVDC	
9	DCV	-00.362mVDC	
Range		Function	Back
Auto 50 mV		DCV	

- Clear the manual record:** Press the **Clear** softkey to clear all data in the data table. (Note: because manual and automatic records share the same data table, automatic readings are also erased.)



### Auto Record

- Configure the parameters:** Press the front panel **Record** key, press the **Auto** softkey. Press the **Point** softkey to specify the total number of readings to record. The range is

1 to 1000.

Press the Interval softkey to specify the time interval between readings. The range is 15 ms to 9999.999 s.

●Trigger			Auto
NO	MODE	VALUE	Point
1	DCV	-00.362mVDC	1000
2	DCV	-00.362mVDC	Interval
3	DCV	-00.362mVDC	0000.015
4	DCV	-00.362mVDC	Start
5	DCV	-00.362mVDC	
6	DCV	-00.362mVDC	
7	DCV	-00.362mVDC	
8	DCV	-00.362mVDC	
9	DCV	-00.362mVDC	
Range		Function	Back
Auto 50 mV		DCV	

2. **Record data:** Press the Start softkey to start auto record. The  icon will show up on the top of the display. Press the End softkey to stop recording, the data table shows the readings taken. Press  or  keys to turn the page.

**Note:**

- Automatic recording function supports switching measurement function.
- In auto range, the relay switch may cause jitter, the data at this time is invalid. It will last about a few hundred milliseconds, and the data acquired in this period will be marked as "invalid".
- When the dual display is enabled, only the reading of main display function can be saved.



## 3. Troubleshooting

### 1. The instrument is powered on but no Display.

- 1) Check if the power is connected properly.
- 2) Check if the line fuse which is below the AC Mains Input is used appropriately and in good condition (see page 17, *Appendix C: Line Fuse Replacement*).
- 3) Restart the instrument after the steps above.
- 4) If the problem still exists, please contact us for our service.

### 2. The reading does not change when a current signal is input.

- 1) Check whether the test lead is correctly inserted into the current input terminals.
- 2) Check whether the DCI or ACI measurement function is enabled.
- 3) Check whether the DCI measurement function is used to measure AC current.

If you encounter other problems, try to reset the settings, or restart the instrument. If it still cannot work properly, please contact us for our service, and provide your device information. (Press the front panel  key)

## 4. Appendix

### Appendix A: Enclosure

Standard Accessories (subject to final delivery):



Quick Guide



Test lead



Crocodile clip



Power Cord

( AC power supply model )



Spare Fuse

( AC power supply model )



USB to DC cable

( DC power supply model )

### Appendix B: General Care and Cleaning

#### General Care

Do not store or leave the instrument where the liquid crystal display will be exposed to direct sunlight for long periods of time.

#### Cleaning

To clean the instrument exterior, perform the following steps:

1. To prevent electrical shock, shut down the instrument, disconnect the power, and disconnect all test leads before cleaning.
2. Clean the outside of the instrument using a wet soft cloth not dripping water. Do not make any scuffing when cleaning the LCD screen. To avoid damage to the instrument, do not use any corrosive chemical cleaning agent.

**Caution:** To avoid any damage to the instrument, do not exposed it to any sprays, liquids, or solvents.



**Warning:** Before power on again for operation, it is required to confirm that the instrument has already been dried completely, avoiding any electrical short circuit or bodily injury resulting from the moisture.

---

## Appendix C: Line Fuse Replacement (Only for AC power supply model)

The line fuse is in the plastic fuse box below the power line input on the rear panel.



**Warning:** Disconnect the line cord at the rear panel and remove all test leads connected to the instrument before replacing the line fuse. Failure to do so could expose the operator to hazardous voltages that could result in personal injury or death.

Use only the correct fuse type. Failure to do so could result in personal injury or instrument damage.

Voltage	Fuse
90 - 240 V AC	250 V, F1AL

To perform the line fuse replacement, follow these steps:

1. Turn off the multimeter, remove all measurement leads and other cables from the instrument, including the power cord.
2. Use a flat-blade screwdriver to remove the fuse box.

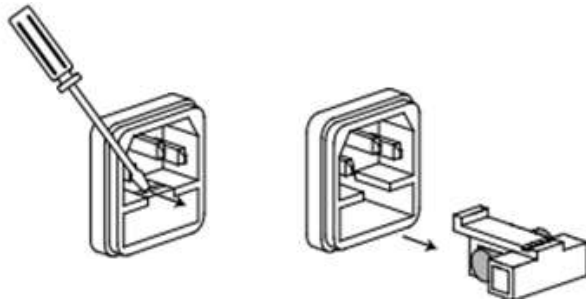

3. Replace the fuse with a new one, install it into the fuse box, and push the fuse box back on to the rear panel.

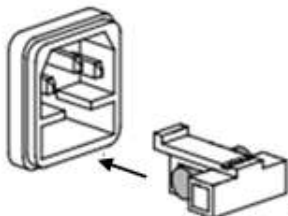

## Appendix D: Charging and Replacement of Battery (Only for DC

power supply model)

During the long-term storage of the device, the battery may be too low due to the self-discharge of the lithium battery and the device cannot be turned on. This is a normal phenomenon.

Please use the attached adapter to pre-charge the device for 0.5 to 1 hour (depend

ding on the storage time) before turning it on. In addition, if the device is not used for a long time, it is recommended to charge it at regular intervals to avoid over-discharge of the lithium battery.

### **Battery Charging**

The lithium battery may not be fully charged at the factory. To fully charge the battery, it takes about 3 hours to charge (when the device is turned off) or subject to the charging indicator. After charging, the battery can supply power for about 10 hours (varies depending on the working state).

When using battery power, a battery indicator will appear at the top of the screen to show battery usage. The  symbol indicates that there are only about five minutes of usage remaining. To charge the battery and power the instrument, connect the USB to DC cable to charge the battery. Turning off the instrument increases charging speed.

### **Charging Method**

Connect the oscilloscope to an adapter or other device for charging via a USB-to-DC data cable or Type-C interface (pay attention to the load capacity of the power supply device, and an adapter of 2A or greater should be used to prevent the device from working abnormally).

### **Note**

To avoid overheating of the battery during charging, the ambient temperature must not exceed the allowable value given in the technical specifications.

### **Replacement of Lithium Battery**

Generally, the battery does not need to be replaced. However, when necessary, it can only be replaced by qualified personnel, and only **lithium batteries of the same specification** can be used.